

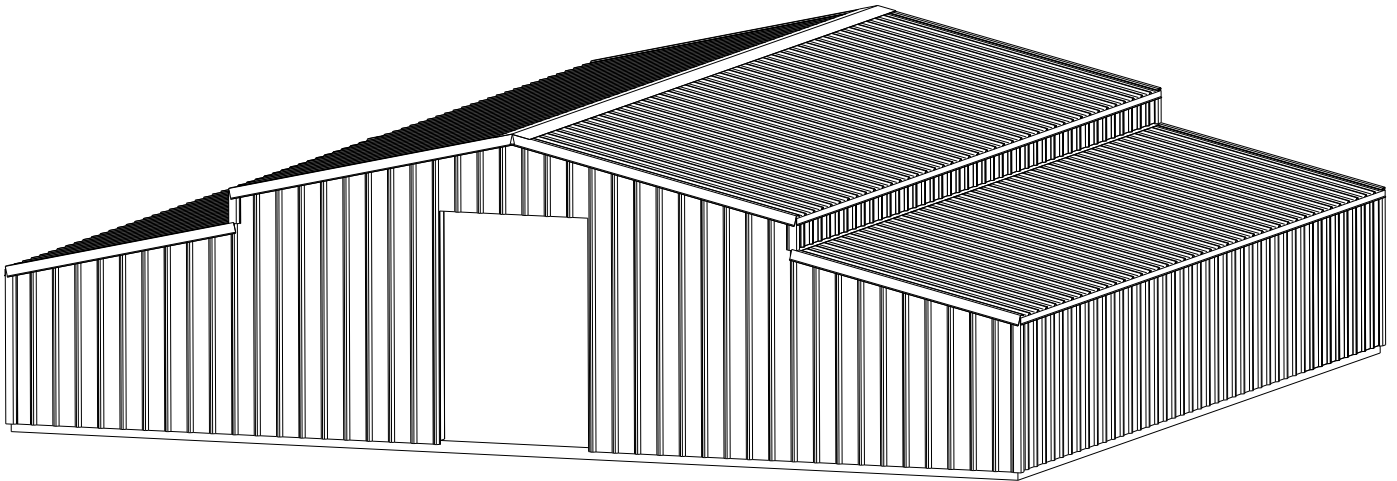

# **Instruction Manual for Installing Cold Formed Steel Buildings**

**American Barn Buildings**



# **Instruction Manual for Installing Cold Formed Steel Buildings**

## **American Barn Buildings**

This manual remains the sole and exclusive property of ACT Building Systems, and is intended only for the sole use of its clients during the period in which a Cold Formed Steel Building is being assembled. ACT Building Systems reserves all rights and privileges associated with this manual, including all copyrights thereto. Any reproduction, dissemination or other use of this information without the express written consent of ACT Building Systems is strictly prohibited.

[www.actbuildingsystems.com](http://www.actbuildingsystems.com)



## TABLE OF CONTENTS

Proper Use of Manual .....	4
Description of Engineering Plans .....	6
Construction of Building .....	8
General Construction Notes .....	8
Step 1 – Initial Set-up .....	9
Step 2 – Installation of Framing .....	12
Step 3 – Installation of Siding and Trim .....	20
Appendix A – Door and Window Framing	
Appendix B – Framing Component Installation	
Appendix C – Trim Component Installation	
Appendix D – Glossary	
Appendix E - Overhang Installation	



## Proper Use of Manual

**Before beginning construction of the building, read the following notifications and notices to understand how this manual is to be used.**

This manual is a reference source, with information on how to construct a typical Cold Formed Steel Building. It is not a set of specific instructions for your building. There are no specific measurements or comprehensive component lists in this manual. For specific measurements and components for your building, please see the engineering plans.

### **Please be aware of the following:**

- This manual is to be used for reference only, and the information contained in it is not specific to your building.
- For information specific to your building, please consult the engineering plans.
- This manual must be used in conjunction with the engineering plans.
- All measurements are to be taken from the accompanying plans and specifications.
- The engineer's plans override any information in this manual.
- This is not a work safety manual, so it is of utmost importance to follow all safety recommendations of OSHA (Occupational Safety and Health Administration).

### **Note:**

- Please adhere to all local building department requirements.
- Do not work on the building in damp conditions and do not walk on roof sheeting in damp or frosty conditions.
- If you are employing a tradesman to erect your building for you, check with the governing authority to see if he needs to be licensed. Also verify that all insurances for both the tradesman and his employees are current.

### **This manual is to be read in conjunction with:**

#### **1. Engineering plans**

The engineering plans contain the foundation plan, all elevations and all connection details specific to your building. The primary purpose of the engineering plans is for obtaining permits for your building. All installation and construction requirements on the engineering plan must followed to ensure that the building complies with all applicable building codes.

#### **2. Construction Package**

The construction package is for reference only, and meant to supplement the engineering plans. It provides more detailed information on where components of your building are to be installed. For example, there will be anchor bolt layouts, sheeting layouts, girt layouts,



and more. All markings on the construction package will correspond with the Usage and Piece Marks columns on the supplied building order.

### **3. Building order**

The building order is a list of all ordered components of the building. Please consult the building order as soon as possible after delivery to ensure all necessary components have been received and to ensure the timely replacement of missing parts.



## Description of Engineering Plans

The engineering plans consist of the following sections:

### 1. Foundation plan

Typically located on sheet 1 of the engineering plans and labeled as 1/1, this displays the foundation of the building and many components in relation to the foundation. Items indicated on the plan include doors and windows (which can be referenced from the above Door and Window Schedule), sidewall/endwall columns and x-bracing.

### 2. Sidewall exterior elevations

Typically located on sheet 1, with the front elevation labeled as 2/1 and the back elevation labeled as 3/1, these display the view of the sidewalls as shown from the outside of the building. Items indicated on the elevations include wall girts, roof purlins, x-bracing and vertical bracing.

### 3. Endwall interior elevations

Typically located on sheet 1, with the left interior elevation labeled as view 5/1 and the right interior elevation labeled as 4/1, these display the view of the endwalls as shown from the interior of the building. Items indicated on the elevations include wall girts, roof purlins, columns, rafters, endwall columns, x-bracing and flybracing

### 4. Mezzanine plan (if applicable)

Because this doesn't exist on every building, its location on the Engineering plans is variable from building to building. This plan shows the layout of the mezzanine. Items indicated on the plan are mezzanine joists, mezzanine girders and columns.

### 5. Connection details

These details are typically shown on sheet 2. They consist of all the connections necessary for the construction of the building and are referenced from the plans and elevations on sheet 1.

### 6. Slab detail

Typically located on sheet 2, this shows the construction of the building foundation slab.

### 7. Member and material schedule

Typically located on sheet 2, this lists materials and members used in the construction of the building. It is referenced throughout the Engineering Plans, as well as this manual.

### 8. General structural notes

These are general engineering notes, listing various requirements for the construction of the building.



### 9. Interior cross section at frame (if applicable)

This section view, typically located on sheet 2, gives a cross section of the building at the typical portal frame and displays the construction and layout of the columns, rafters and knee and apex braces, among other things.

### 10. Section and detail callouts

Various views and details are referenced on the engineering plans through section and detail callouts. Below, you can see 3 of the most typical. Note that typically the top number is the detail or view number while the bottom number is the sheet number.

- 1) **Elevation callout.** Located on the foundation plan these callouts reference an elevation that is from the perspective of the position of the callout in the direction of the arrow. The 2 over 1 means that the callout is referencing view 2 on sheet 1.
- 2) **Cross section callout.** This references a cross section through the section line protruding from the callout. The detail will display this cross section in the direction the flag points. This specific callout references detail Y on sheet 2.
- 3) **Detail callout.** This callout references a detail elsewhere on the plans which gives a more detailed view of the area referenced. This callout specific references detail B on sheet 2.

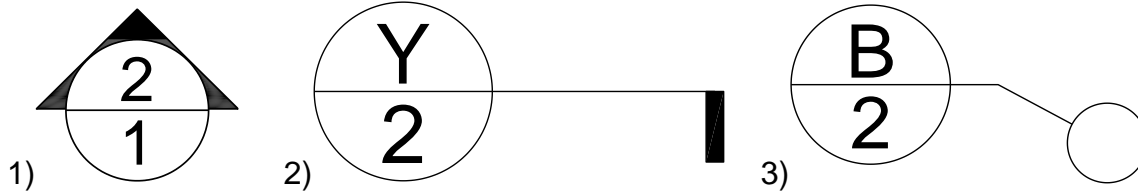



# **Construction of Building**

## **General Construction Notes**

- 1. It is recommended that as much assembly of building components is completed while the components are on the ground as opposed to in the air. An example of this would be measuring and coping knee braces before columns are installed, or installing all necessary clips or brackets to a column before raising and installing the column.**
- 2. Before drilling holes in concrete, ensure that location to drill is 100% correct. If incorrect, building construction may need to be delayed**
- 3. The exact makeup of a bolt assembly can vary by building. Note that although washers are illustrated as part of a bolt assembly, the bolts supplied may instead have a flanged head and nut (washer/head or washer/nut combined). For exact makeup of the bolt assembly, please refer to the building order.**
- 4. When installing trim, keep in mind how water will run. Trim should be installed so water will not flow into the building during normal flow.**
- 5. Framing tek screws have various diameters and lengths. Make sure that when installing framing tek screws, correct screw size, type and number per connection are used, per the engineering drawings and building order. If you have been provided with screws of various length and self drilling tip size, the correct use of screws should be listed on the building order. If not, longer screws that can drill through more material should be saved for those connections that require drilling through a significant amount of steel.**
- 6. When installing all screws that include rubber washers, such as wall and roof screws, care must be taken to tighten these screws the proper amount. If screws are tightened too much or too little, they will not seal properly. Screws should be tightened so that washer has been compressed, but not to such a degree that the washer becomes deformed. If washer becomes deformed, a screw with a fresh washer will need to be re-installed.**





## Step 1 – Building Set-up

Before beginning construction of your building, please complete the following.

### 1. “Check-in” building immediately after receiving shipment from supplier.

Immediately after receiving your steel delivery from supplier, unpack and make sure that all parts have arrived as specified on the building order, which should be provided by your building seller. Note that the building order lists materials from all vendors. Please check delivery against the appropriate vendor section of the building order. If order is not as it should be, please contact building seller immediately. If there is a mistake on the order, supplier will correct order only if notified within 7 days of delivery. If customer fails to check-in building and notify building seller within these 7 days, any extra costs incurred will be the responsibility of the customer.

After “checking in” your building, you may need to store your materials for a length of time before beginning construction. When your steel arrives, it is important to do the following:

- Store the steel so there is adequate airflow over it while it is waiting to be used in the construction.
- Any water that finds its way onto the steel should be removed and the steel dried as soon as possible.

Failing to do this can result in the first stages of corrosion commonly referred to as storage stain. Note that the above tips are not the only storage precautions that you may need to take. Please consult all manufacturer’s storage instructions. If you are concerned about your storage situation you should contact the building seller or supplier and discuss this with them.

### 2. Assemble necessary tools.

To construct your building, ACT recommends that you acquire the following tools:

- Sharpie markers
- Carpenters pencil
- Pencils and paper
- Tape measures
- Chalk line with extra chalk
- String line
- 4’ level
- Builders square or angle square
- Safety glasses
- Right-cutting and left-cutting sheet metal snips
- 3/4” or larger hammer drill w/ SDS-compatible chuck
- 1/2” and 5/8” Powers “wedge-bits” drill bits
- Impact wrench
- (4) 6” C-clamp vice grips
- Spud wrench or bull pin
- Tek screw gun



- Electric drill
- Nibbler or Sawzall
- Angle grinder
- Circular saw or chop saw with necessary steel cutting blades
- Multigrips or pliers
- Rivet gun
- 10-lb sledge hammer
- Caulking gun
- Silicone caulking
- Air puffer
- $\frac{1}{4}$ " and  $\frac{5}{16}$ " magnetic hex nut drivers
- $\frac{1}{2}$ ",  $\frac{5}{8}$ ",  $\frac{3}{4}$ ", and  $\frac{15}{16}$ " bolt sockets
- Utility knife
- Two-sided tape
- Wrenches
- Ropes
- (2) 8'-12' step ladders
- (1) 22'-28' extension ladder
- Power and extension cords
- Electric shears
- Material lift

The following tools are optional, but are recommended for ease of installation:

- Fork lift
- Scaffolding
- Scissor lift
- Boom lift
- Crane with a minimum 70' boom reach (professional contractors only)

Note that other tools may speed the process of building installation. The above tools are merely the minimum needed to install your building. If you have any questions regarding tools, such as recommended brands, please contact your building seller.

### **3. Check that the building foundation complies with engineering plans.**

If your building uses a foundation slab, then ensure:

- a) The slab is level.
- b) The slab is diagonally square. (See Glossary.)
- c) The slab is the exact size as your building will be.

If your building uses pier footings, ensure piers are of correct depth, square and clear of any loose soil.

### **4. Clean and clear slab.**

Completely clean slab, making sure it is clear of all dirt and/or debris as well as any other obstructions.

### **5. Set out the location of all columns and all anchor bolts.**



First, set chalk lines on both the sidewall and the endwall of the building and leantos. Note that this chalk line will be set in from the edge of the slab the size of the wall girts. Sidewall chalk lines will be set in from the edge of the main building. Thus, if you have 4" sidewall girts, the chalk line on the sidewall will be set in 4 inches. Note that the size of the sidewall and endwall girts can be different. Please check the engineering plans for specific size of sidewall and endwall girts.

Also, chalk out the center line of your bays. Bay spacing is found on the engineering plans.

After chalking lines on slab, mark out the locations of your columns. Note that the edge of the single- and double-sidewall columns are set on the edge of the sidewall chalk line, and these columns are centered on the bay chalk lines. The same is true of the endwall columns being set on the edge of the endwall chalk line. Note, however, that the corner columns are set in off the sidewall, with the edge of the column lining up to the edge of the sidewall chalk line. They also may be set in off the endwall, as the back of the corner column will line up with the back of the endwall girt chalk line. When the endwall girts are 6" or larger, the corner column will be set in from the edge of the slab. This is illustrated on the following page.

Note that the corner columns will always consist of a single column. Your interior sidewall columns will either be all single columns or all double columns. This is not illustrated on the following page, and both single and double columns are shown to illustrate both instances.

Note that it is imperative that the lines are chalked. All columns must line up exactly. Using chalk lines ensures this will occur, even if slab is not completely square. However, slab must be diagonally square to ensure all columns line up correctly.

Once complete setting out the location of your columns, mark out the locations of your anchor bolts holes. The exact location of the holes will vary based on your sidewall and endwall column types. The exact location of your anchor bolts can be determined by used the Bolt Setout plan, which can be provided by your building seller. Note that bolts for a single CEE assembly will fall outside the CEE, while bolts for a double CEE assembly will be contained in the CEE.

It is imperative that the bolt locations are marked out in exactly the right location. If bolts holes are drilled in the wrong location, building construction will need to be delayed until the concrete slab is fixed.

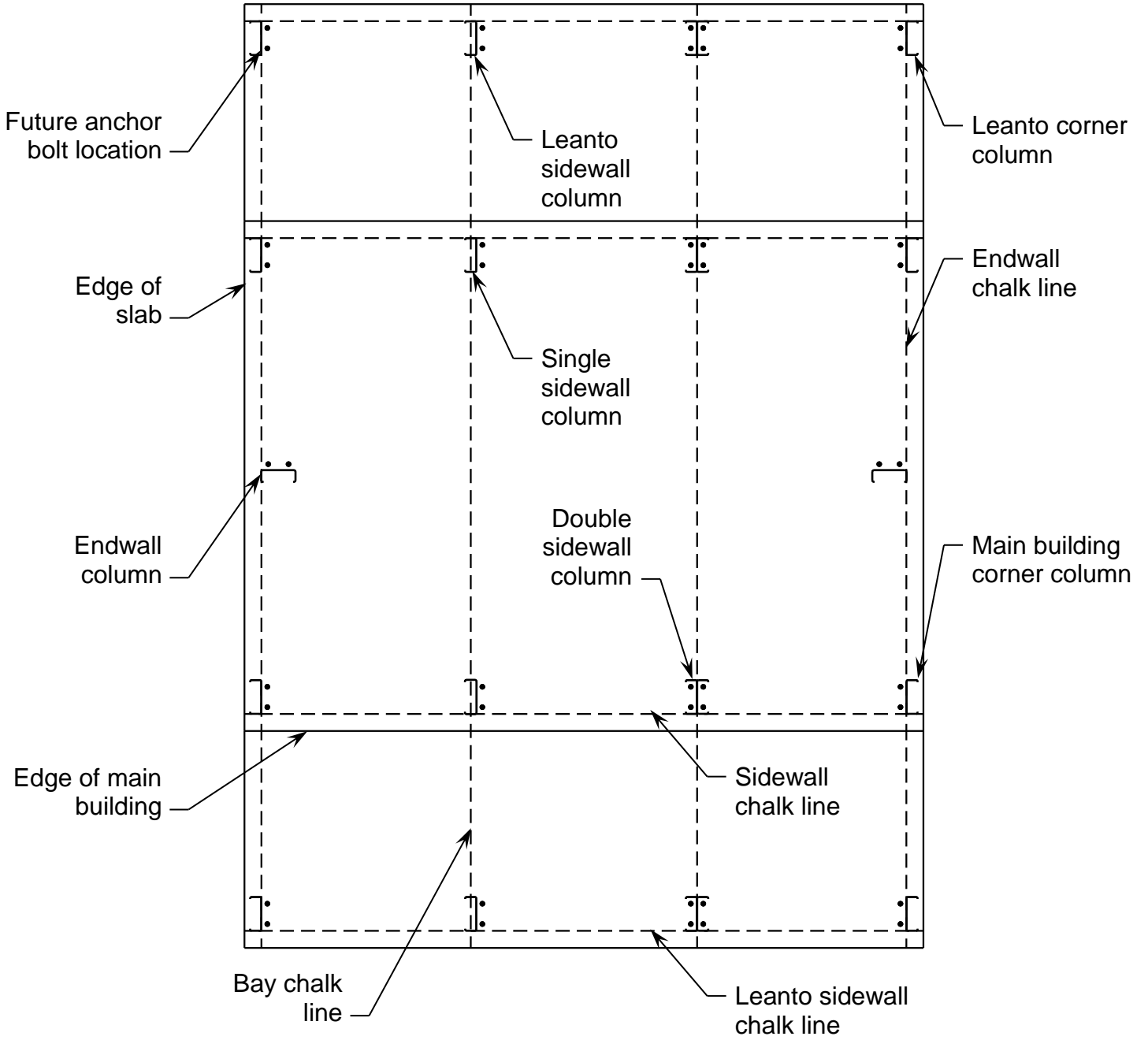



## Step 2 – Installation of Framing

Note that the following section is to be used in conjunction with Appendix B, which contains specific instructions for installing all framing components described below. For example, all specific instructions on installing haunch brackets are found in the haunch bracket installation section of Appendix B. Please refer to Appendix B as you proceed through the instructions below.

For information on installing door and window framing, please refer to Appendix A.

To begin erection of the building, you should start by constructing the framing on a bay that contains x-bracing and has no window or door openings. Preferably, you should start on an interior bay. Note that the descriptions and illustrations below are for a building with single columns and rafters. Please see engineering plans for any questions on your specific building components.

### 1. Stand and anchor columns on interior bay with x-bracing.

First connect the haunch brackets, leanto brackets and any necessary mezzanine brackets to the column CEEs. Then, stand up columns and set anchor bolts in pre-drilled and cleaned holes, attaching the columns to the foundation according to locations laid out on engineering plans. Attach any needed column stiffeners to your columns at this time.

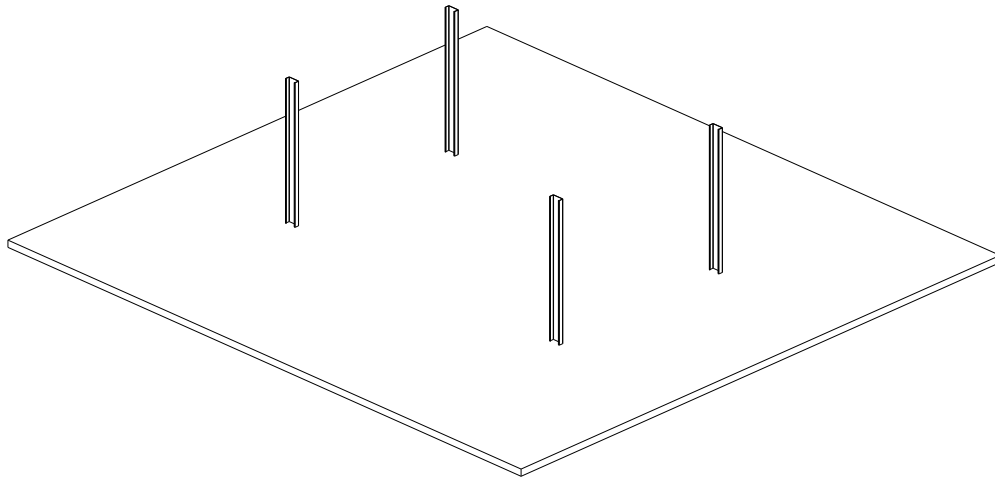

### 2. Add sidewall girts and eave purlins.

Connect the columns with wall girts and eave purlins. Before securing, make sure that all columns are plumb (truly vertical). Then temporarily brace the bay to make sure the columns stay plumb. Pro Tip! Use ratchet strapping to temporarily “x-brace” the bay until final x-bracing is installed in step 5.

When installing girts in this first bay, ensure that the attaching flange of the girt is connected to the columns, with the attaching flange connected so it is pointing upward. Note that if LGSIs are to be used for the wall girts, it is important that the wider flange is connected to the rafter. Each LGSIs should have one flange slightly wider than



the other so that girts will more easily interlock, and they must be installed in this manner. For more information, please see wall girt installation section in Appendix B.

Note that in many American Barns, there may not be any wall girts or eave purlins to install on the main columns. If this is the case, brace installed columns and proceed to next step.

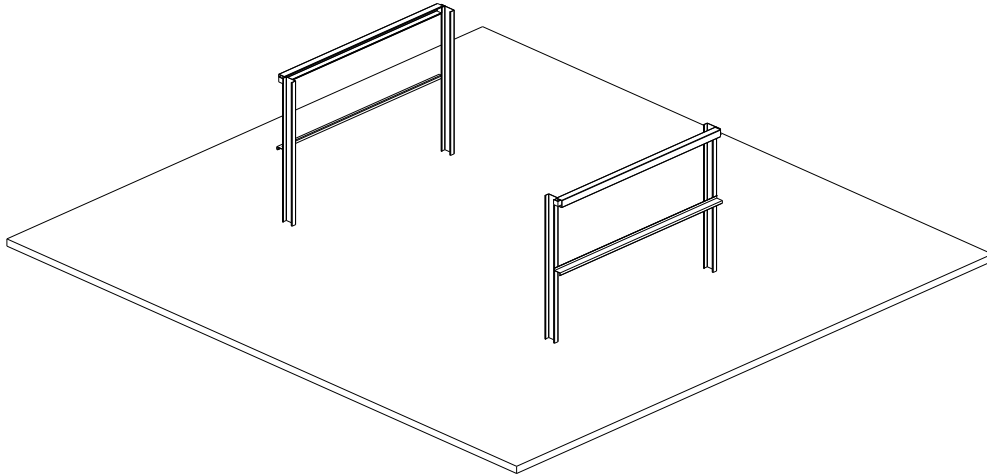

### 3. Add first rafter with apex brace.

Connect two rafter CEEs together using the apex bracket. Raise the rafter into place and connect to the columns. (See haunch connection section.) Secure connected rafter with rope so that rafter will stay plumb and level. Before tightening rafter bolts, make sure that distance from edge of rafter to edge of rafter equals the distance from the edge of column to edge of column. If this is not precise, columns will be pushed out of plumb when rafter is installed.

Install knee and apex braces as directed on the engineering plans.

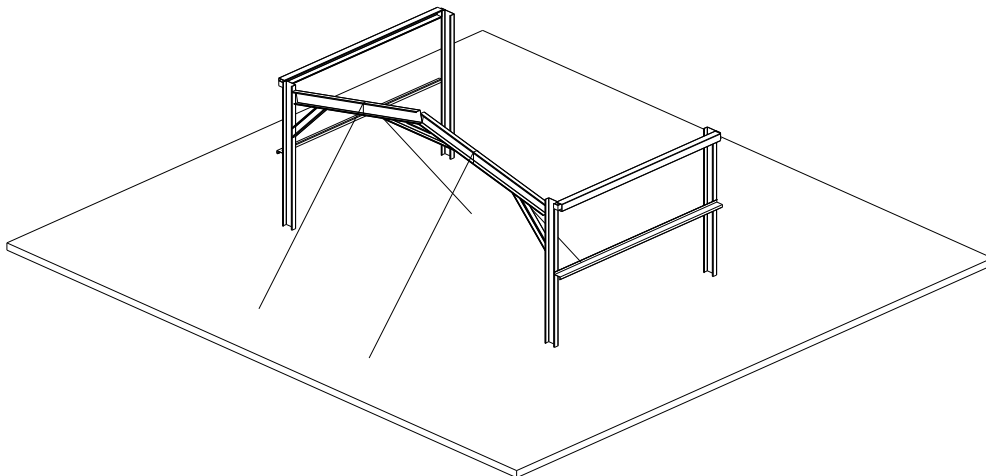



#### 4. Add second rafter with apex brace and stabilize with roof purlins.

Install the second rafter. After stabilizing rafter and making sure that rafter is plumb and level, connect to first rafter using roof purlins. Install all purlins for that bay, at spacing and location specified in the engineering plans.

Ensure that the attaching flange of the purlins is connected to the rafter in this first bay with the long flange pointing downhill. If LGSI sections are being used for the purlins, note that it is important that the wider flange is connected to the rafter. LGSI sections are made to interlock for easier installation, and they must be installed in this manner. For more information, please see roof purlin installation section in Appendix B.

Install knee and apex braces. Exact location specified on engineering plans.

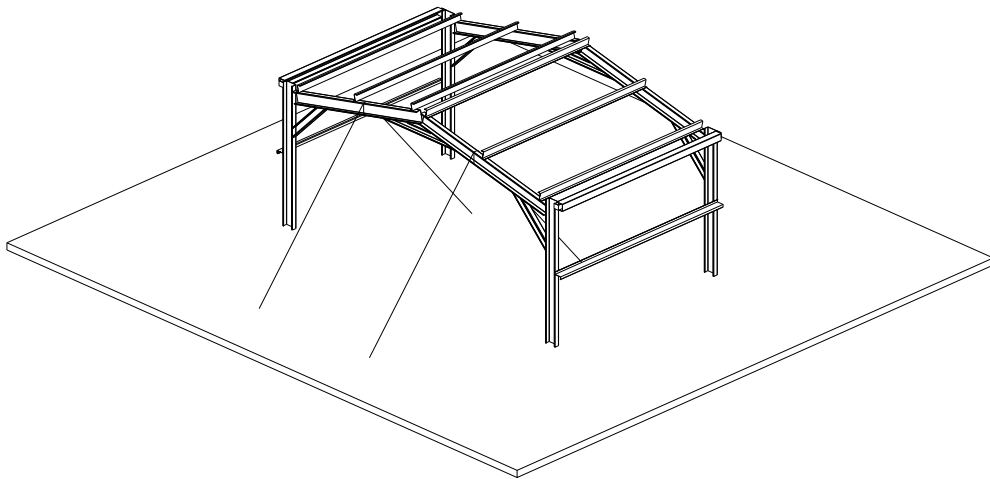

#### 5. Install x-bracing.

After ensuring all columns, rafters, girts and purlins are level and plumb, install x-bracing per the engineering plans. Ensure that x-bracing is snug, but not overly tightened. The x-bracing must be tight enough to prevent movement but not so tight as to pull the columns and rafters out of level.

If sidewall bay does not contain x-bracing, please secure with temporary bracing (such as ratchet strapping) to ensure that bay stays stiff through rest of installation process.

You may remove rope ties at this time.

*(Illustration on next page)*

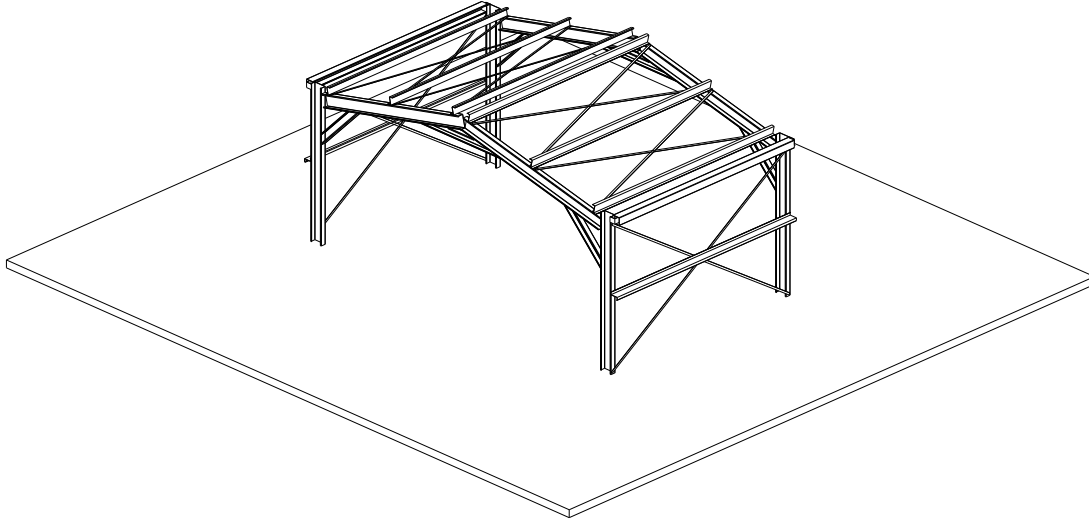

## **6. Install mezzanine components in constructed bay, if applicable.**

If your building has a mezzanine, it can be installed at any point after this step in the previously constructed bays. Earlier installation can provide greater stability to your building components during construction, and will ensure building compliance with the engineering plans. Please refer to Appendix B of this manual for instructions on installing mezzanine components.

## **7. Install leanto columns and rafters, if applicable.**

*\*\*\* If the main building has wall sheeting installed under the leanto roof, which is standard in most open leanto configurations, the leanto framing should not be installed until after the main building wall sheeting is installed. Please see your engineering plans and Appendix B – Leanto Rafter Installation for specific installation instructions and illustrations. \*\*\**

Begin by tipping up a leanto sidewall column and securing to slab by drilling and setting with anchor bolts, exactly as the sidewall columns were installed. Then secure leanto rafter, connecting from the column of main building column to the leanto column. (See sections on leanto rafter installation and haunch bracket installation.) Repeat this process for all adjacent leanto columns and rafters for bay.

Install any required knee braces on leanto columns and rafters.

*(Illustration on next page)*



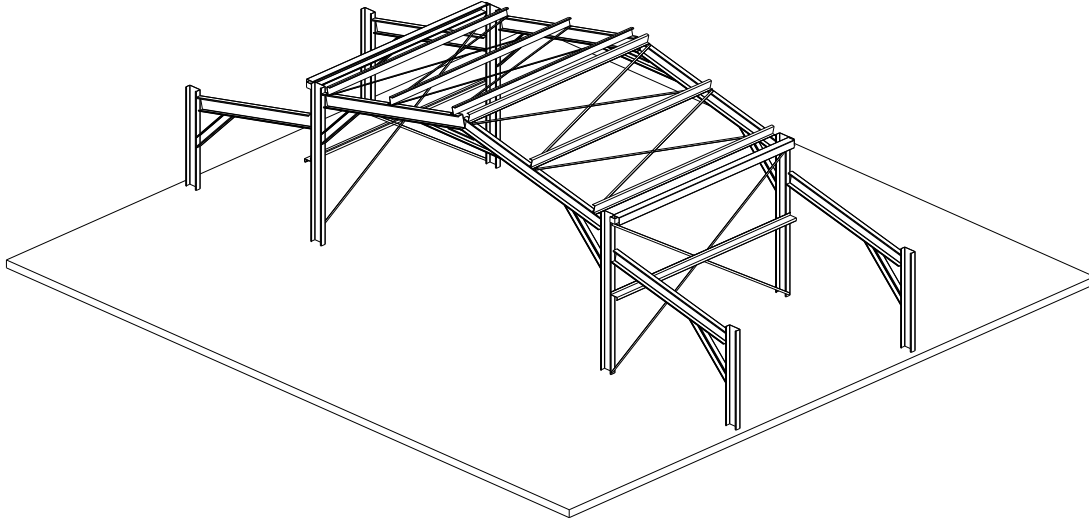

### **8. Install all leanto girts, purlins, and x-bracing.**

Install all remaining girts, purlins, and x-bracing on the leanto sections of the bay. Use the same methods described above. Please see Appendix B for more information on all components. Before securing, ensure that all components are level and plumb.

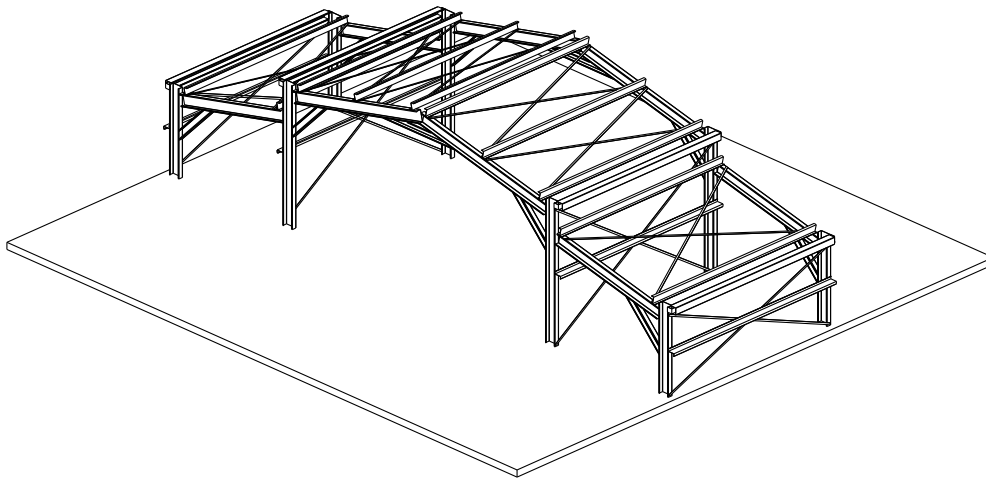

### **9. Construct the remaining interior bays and complete all framing.**

Following the instructions outlined above, install the necessary columns, rafters, mezzanine components, girts, purlins, and x-bracing for the remaining interior bays. Remember to ensure that all components are level and plumb. After installing all columns, rafters, girts, and purlins, install all flybracing per the engineering plans.

Note that not all bays will have all the same components. Please refer to the engineering plans for exact number and location of all components.

Also note that certain bays require door framing to be installed in place of wall girts. Please refer to the engineering plans for location. Also see Appendix A for instructions on how to install door and window framing.



### 10. Install corner columns.

Stand up corner columns and drill and set anchor bolts. Then, after making sure columns are level and plumb, connect to sidewall column by installing eave purlins, wall girts and door framing per engineering plans.

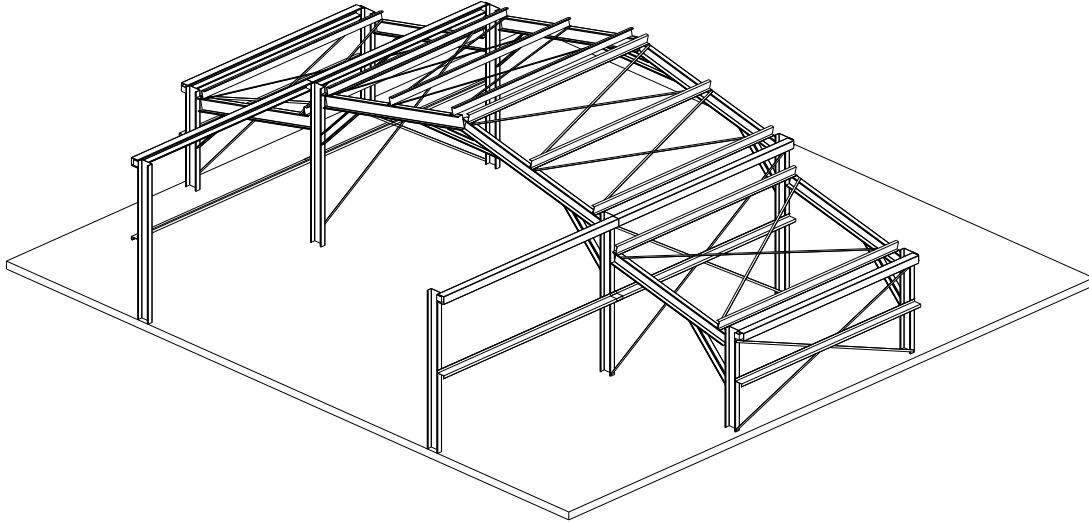

### 11. Install end rafters.

Install end rafter. After making ensuring it is level and plumb, connect to interior rafters by installing roof purlins for that bay.

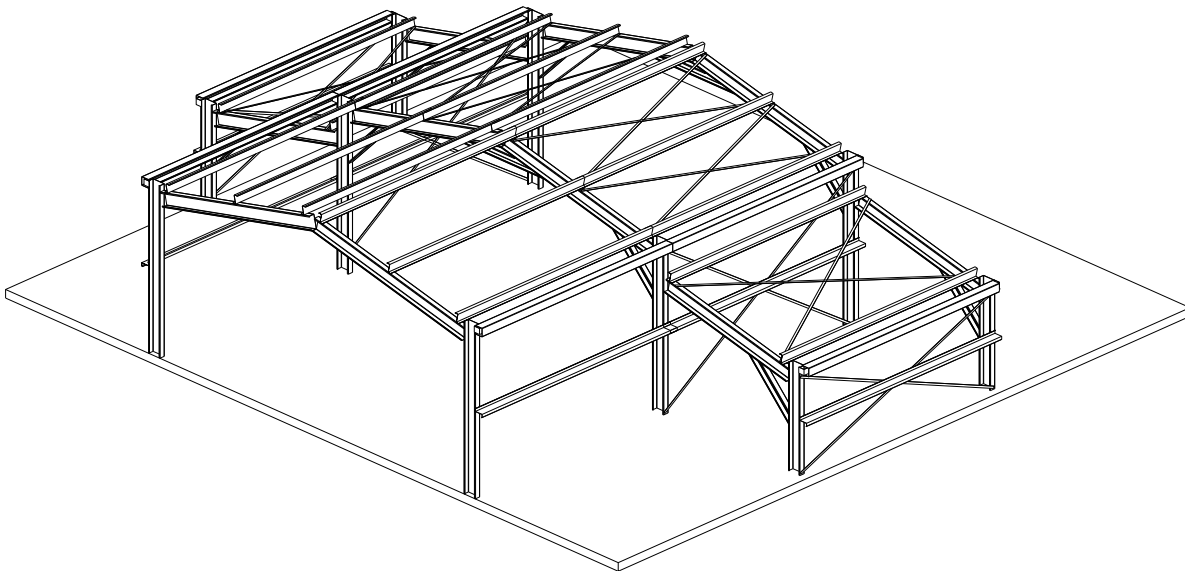



### 12. Complete framing of endwall.

Install the endwall columns. Location and number are located on engineering plans.

Install all mezzanine components, wall girts, door framing and flybracing per engineering plans.

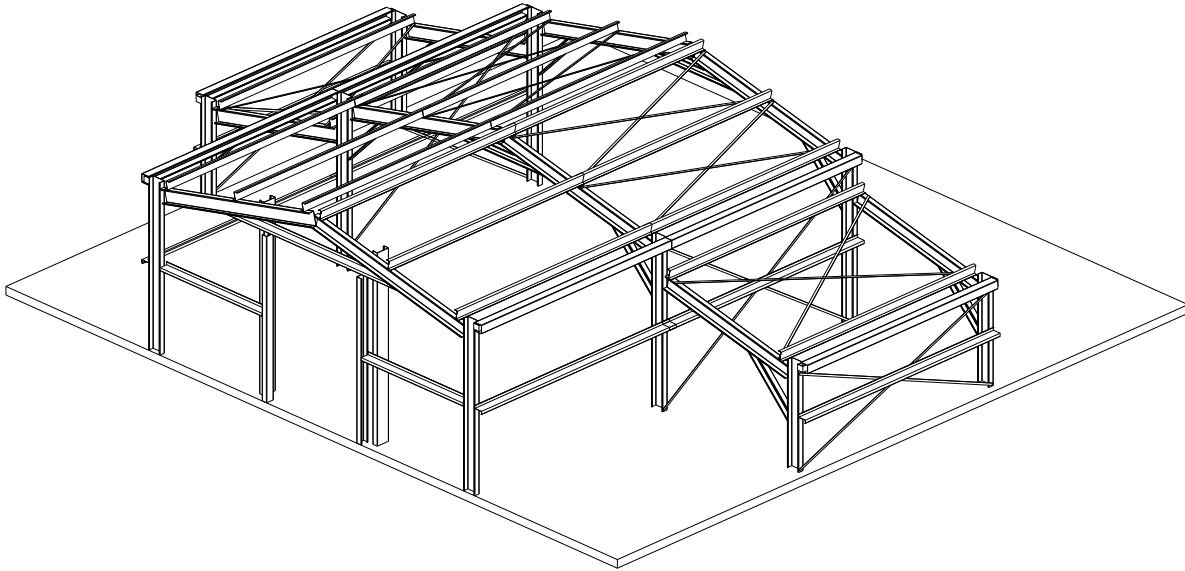

### 13. Complete framing of leantos on endwall.

Install leanto corner columns, endwall rafters and any leanto endwall columns. Also install sidewall girts, endwalls girts, purlins, door framing and any required flybracing.

Ensure all framing components are plumb and level.

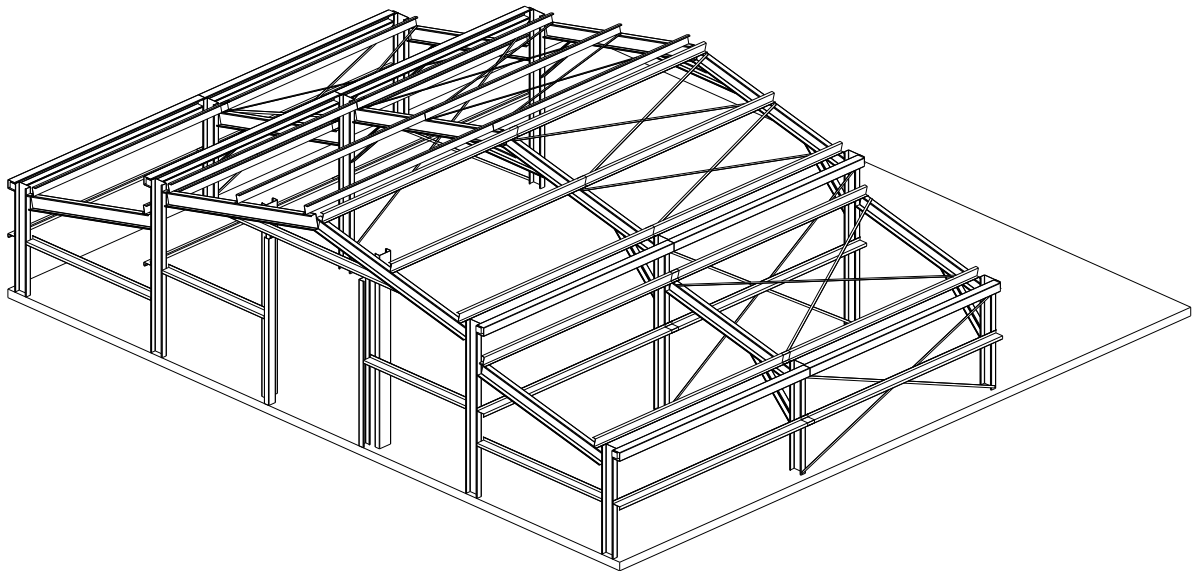



#### **14. Complete framing on opposite end.**

Using the method described above, install the remaining corner columns and end rafters, ensuring that they are installed level and plumb.

Install the endwall columns. Location and number are located on engineering plans.

Install all wall girts, door framing and flybracing per engineering plans.

Install all leanto framing components.

Ensure all framing components are plumb and level.

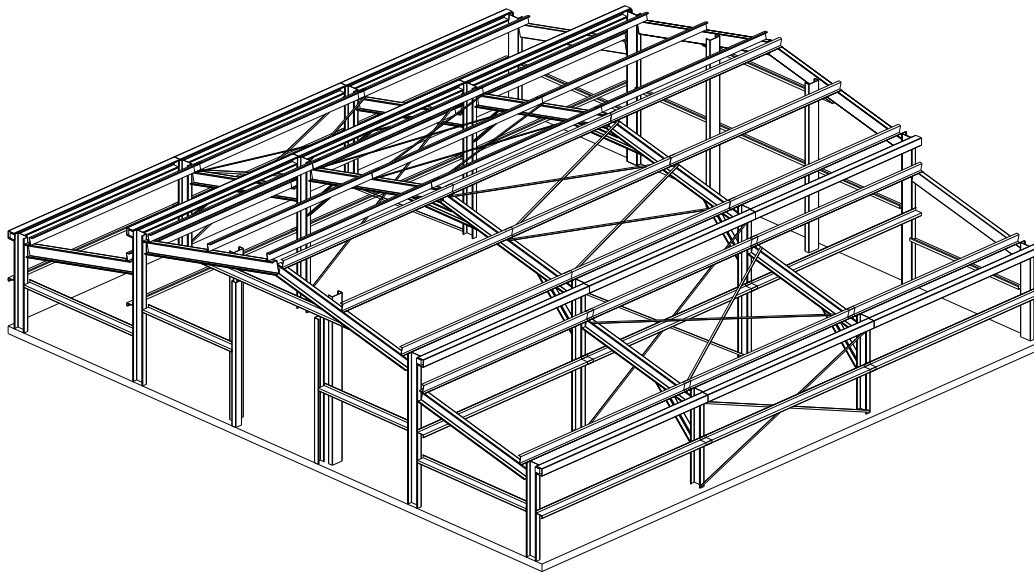

#### **15. Install any base angle, corner angle and rake angle provided in building kit.**

After completing all framing, install any base angle, corner angle and rake angle that is in your building kit. For installation of base angle, corner angle and rake angle please see Appendix B.

#### **Alternate framing method:**

If you possess the equipment, it can be easier to construct the buildings portal frames (which consist of columns, rafters, and all applicable knee and apex braces) on the ground and tip up or raise the portal frame all at once. However, because of the weight of these members, this process often requires heavy equipment such as a fork lift or a crane. Do not attempt this without adequate equipment and without taking ample safety precautions.



## Step 3 – Installation of Siding and Trim

Note that the following section is to be used in conjunction with Appendix C, which contains specific instructions for installing all trim components described below. For example, all specific instructions on installing wall sheeting are found in the wall sheeting section of Appendix C. Please refer to Appendix C as you proceed through the instructions below.

Note that trim will vary greatly with each building based on the building options selected. Please see your order to ascertain what trim will be on your building. Note that this manual provides instructions for basic types of trim and siding ordered by ACT's ordering system. You may or may not have all of the components described below. If you have additional questions, please contact your building seller.

### **1. Install windows.**

Install all windows per manufacturers' instructions.

### **2. Install trim around doors and windows.**

Install necessary head/jamb cover, which is installed only on the overhead door jambs and header. After installing head/jamb cover, install head/jamb trim. Note that head/jamb trim is installed on all three sides of doors and all four sides of windows.

### **3. Install base trim**

If your building kit includes base trim, install that before proceeding with installation of wall sheeting.

### **4. Install leanto sidewall sheeting, insulation, and closure strips.**

After completing any base trim, install insulation, leanto sidewall sheets and closure strips. For instructions on this process, please see the Wall Sheeting Installation section in Appendix C. Note that the sidewall sheets should extend about 1" below the edge of the slab and extend to just below the eave purlin. Also note that the sheeting should start at the back side of the building so that when you look at the building, the sheeting laps do not stand out. Note that sheeting will have to be trimmed around doors and windows.

*(Illustration on next page)*

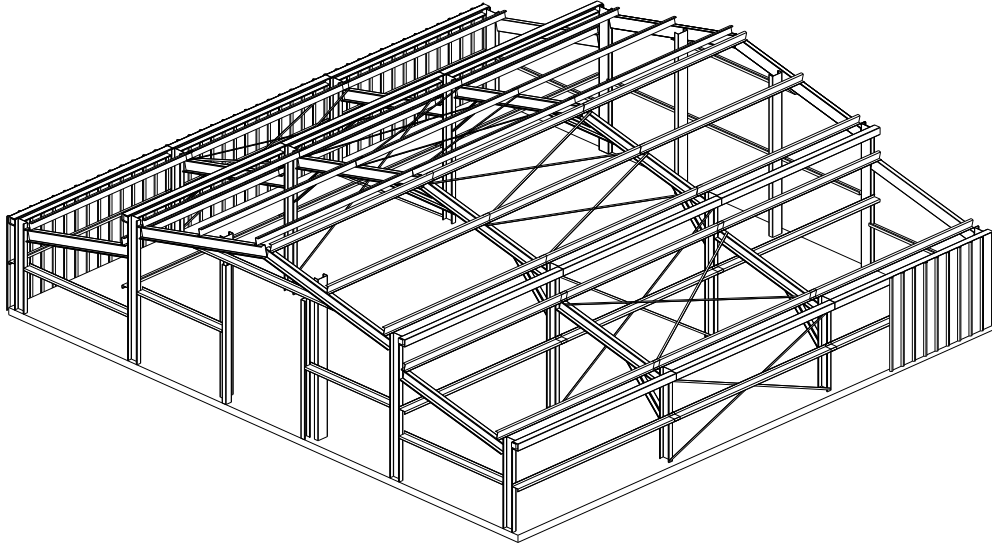

**5. Install endwall sheathing, insulation, and closure strips.**

After sidewall sheets are installed, install endwall sheets. These are installed in the roughly same manner as sidewall sheets. However, after sheets are attached, these sheets will need to be trimmed to match the roof slope.

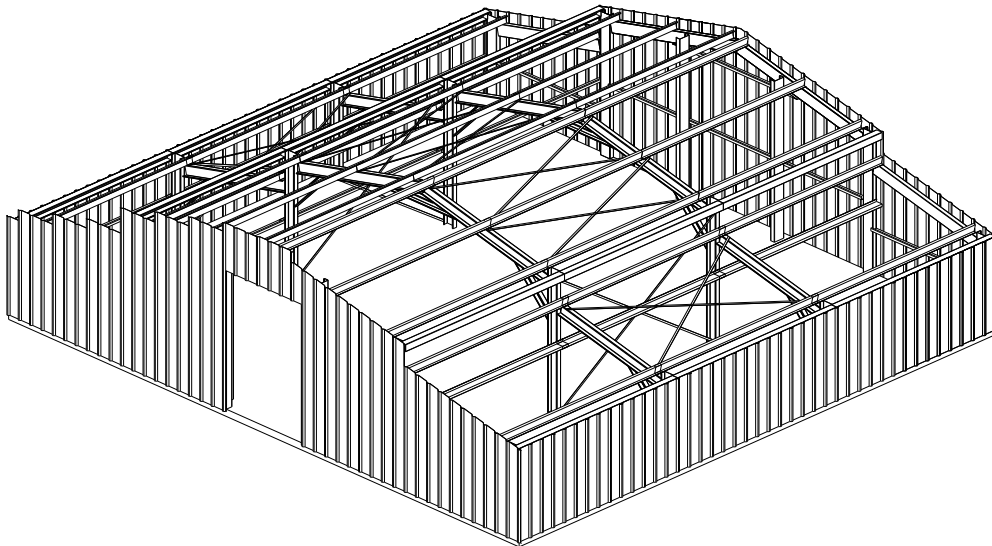

**6. Install corner trim.**

Install corner trim on all building corners after all wall sheathing is complete.

**7. Install eave trim or box gutters along top of leanto sidewall.**

After installing corner trim, install eave trim or box gutters if provided in building kit.

### **8. Install leanto roof sheeting, skylights, insulation and closure strips.**

Install roof insulation, closure strips, roof sheets and skylights. Sheeting should start at the side opposite the direction of the prevailing winds.

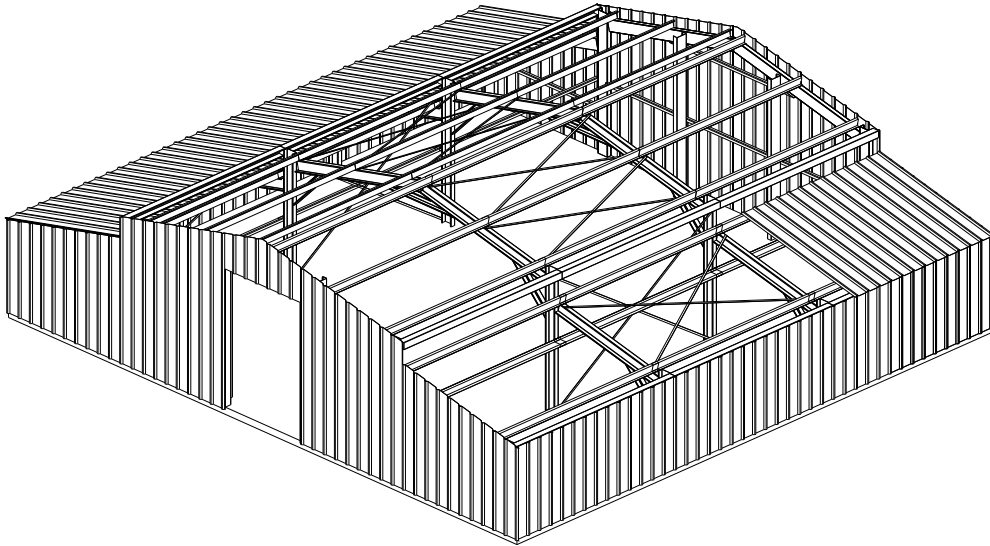

### **9. Install pitch break trim, pelmet sheets (including any insulation and closure strips) and corner trim.**

Install pitch break trim at the top edge of the leanto sidewall sheets, and any closure strips between the pitch break trim and the leanto roof sheeting.

Next, install pelmet sheeting, insulation and closure strips. Note that pelmet sheeting, insulation and closure strips are installed exactly as on a normal sidewall, except sheeting and insulation run from the eave purlin of the main building to the top of the pitch break trim and leanto roof sheeting.

Install corner trim around the ends of the pelmet sheeting so corner trim runs the length of the pelmet sheet.

*(Illustration on next page)*

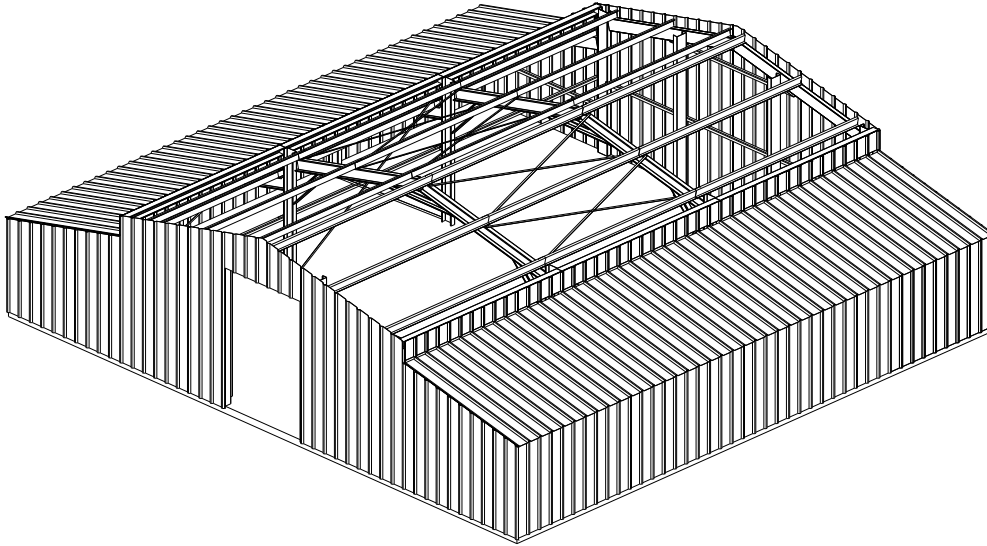

**10. Install eave trim or box gutters along top of pelmet.**

After installing pelmets and corner trim, install eave trim or box gutters of the top of the pelmet sheathing, if provided in building kit.

**11. Install roof sheathing, skylights, insulation and closure strips.**

Install roof insulation, closure strips, roof sheets and skylights. It is best to roof one side of the roof, and then sheet the opposite side only after the first side is entirely sheathed. Also, sheathing should start at the side opposite the direction of the prevailing winds.

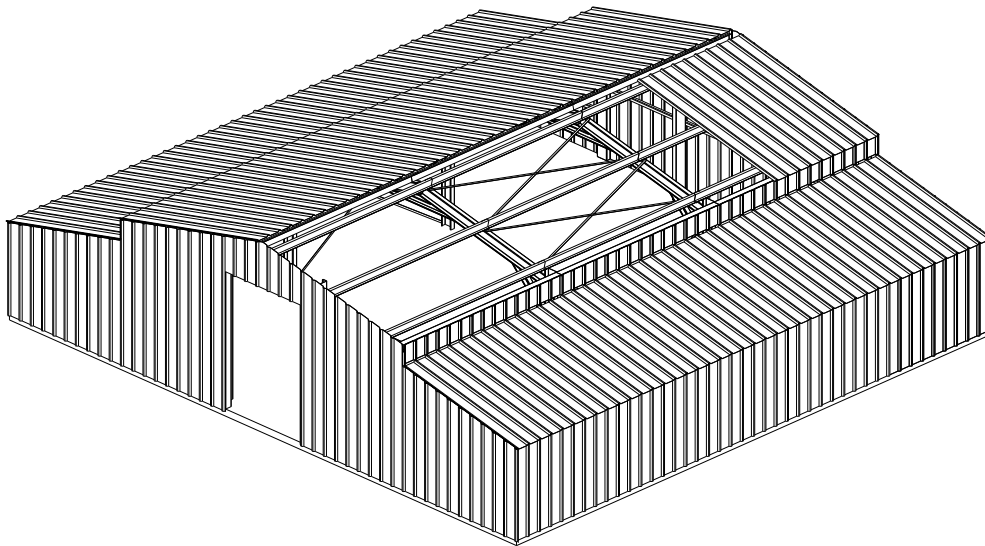

**12. Install rake trim on leantos and main building.**

Install rake trim at the tops of all endwalls, including the main building and leanto endwalls.

**13. Install ridge cap and closure strips.**

Install ridge cap along the ridge of the building, installing any provided apex closure strips.





**14. Install sculptured gutters.**

After installing all other trim and sheeting, install sculptured gutters.

**15. Install gutter downspouts.**

After gutters are installed, install gutter downspouts.

**16. Install all doors.**

After installing all sheeting and trim, install all doors per manufacturers' instructions.