

INSTALLATION & MAINTENANCE

Commercial & Industrial Sectional Doors

Model: _____ Serial No. _____

(Provided on label on interior door surface)

Size: _____

Retain This Booklet For Future Reference
This Manual Contains Important Safety Information

 **Clopay**[®]

BUILDING PRODUCTS
A Griffon Company

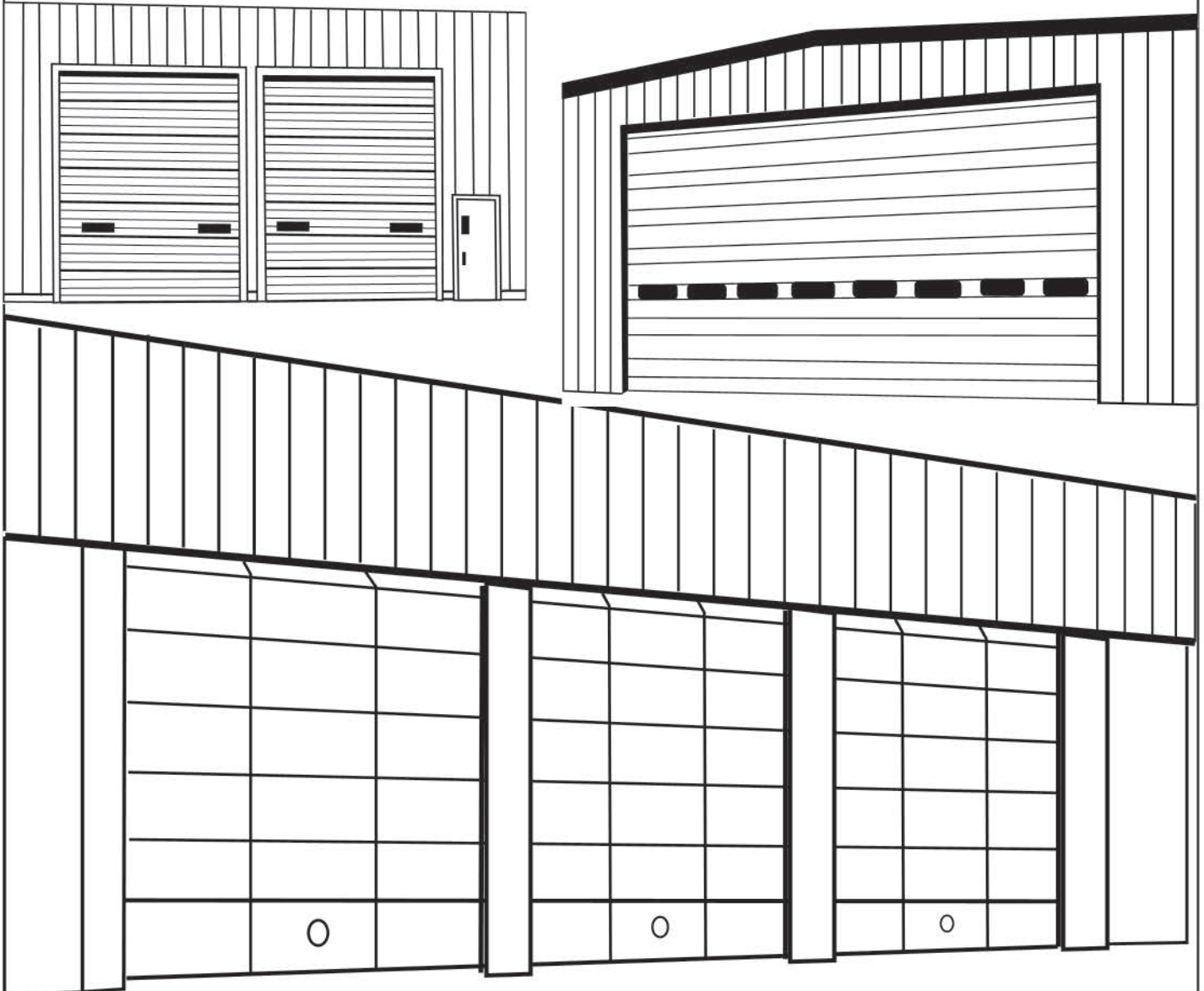

COMMERCIAL HOTLINE • 1-800-526-4301

Dear Clopay Customer,

Thank you for purchasing a Clopay Garage Door. Your new Clopay Garage Door was built to meet the highest industry standard and to provide you with years of dependable performance.

This manual contains important safety, installation and maintenance instructions. Carefully follow the instructions and maintenance recommendations. Please keep this manual for future reference.

If you should require any assistance or additional information, please call Clopay at 1-800-526-4301.

Thank you again for choosing Clopay!

Sincerely,
Clopay Building Products Company



America's Favorite Garage Doors™

Table of Contents

Introduction and Opening Preparation

Safety Information	3-4
Things to Know Before You Begin	5
Removing the Existing Door	6
Preparing the Opening	6

Installing the New Door

Preparing and Installing Door Sections	7
C-Channel Attachment (Non-Windload Doors Only)	10
Lock Installation	12
Track Installation	15
Standard Radius	17
Roof Pitch	23
Spring Installation	18
Spring Winding	19
Low Headroom Rear Mount	24
Low Headroom Front Mount	26
Vertical Lift	27
High Lift	28

Maintenance/Adjustments/Options

Final Adjustment and Maintenance	22
Attaching an Automatic Opener	29
Painting and Windows	30
Quick Turn Bracket	31
Pass Door Instructions	31

SAFETY INFORMATION

IMPORTANT!

**To Protect Yourself From Injury,
Carefully Read The Following Safety
Information And Warnings Before You Install
Or Attempt To Repair Your New Garage Door**

- You can install your new garage door yourself IF...
 1. you have help (weight can vary from 150 lbs. [70 kg] up to 2,000 lbs. [900 kg]);
 2. you have the right tools and reasonable mechanical aptitude or experience; and
 3. you follow these instructions very carefully.In particular, please note that:
- Garage doors use springs to balance them. Generally, there are two types of springs used — **extension springs and torsion springs. If your old door uses torsion springs, do not attempt to remove the door or the springs yourself.** Have a qualified door repair service remove them. Attempting to remove a torsion spring assembly and/or any red-colored fasteners without proper training or tools may result in an uncontrolled release of spring forces which can cause serious or fatal injury.
- The brackets at the bottom corners of your garage door are under great tension. **Do not attempt to loosen any bracket fasteners** and/or any red-colored fasteners except when and as directed in detail in the following instructions. Otherwise, the bracket could spring out with dangerous force.
- When installing a door with torsion springs, always use solid steel winding bars. Winding bars are available from many professional door installers. **The use of screwdrivers or any substitutes for winding bars will risk severe injury.** See page 19 for further **safety instructions regarding winding bars.**
- Keep hands and fingers clear of section joints, track, and other door parts when the door is opening and closing to avoid injury. The lift handle and pull down rope are located for safe operation as well as easy use.
- **Extension spring doors must never be operated without a properly installed spring containment cable.**
- Bolts must be installed at the rear end of horizontal tracks. These act to stop the rollers and keep the door from rolling off the back of the track.
- **Only the track and hardware specified and supplied with the door should be used.**
- Express warranties apply only to doors installed using original, factory-supplied sections, parts, and hardware installed in strict accordance with these instructions.

SAFETY INFORMATION

IMPORTANT!

**To Protect Yourself From Injury
Carefully Read The Following Safety
Information And Warnings Before You Install
Or Attempt To Repair Your New Garage Door**

- Track installations must use sway braces on the rear track hangers to prevent sideways movement. If the tracks are not firmly stabilized they might spread, allowing the door to fall and cause severe injury and damage.
- The center torsion spring assembly uses a wooden pad (2" x 6" x 12" [51 mm x 152 mm x 305 mm] minimum) minor steel plates ($\frac{1}{4}$ " thick x 10" x 12" [6mm x 254 mm x 305 mm] minimum) that **must be of good quality and firmly attached to the wall**. Four $\frac{3}{8}$ " x 3" [10 mm x 76 mm] lag screws should be used to attach wood structure. The wood needs to be made of a Grade 2 or better Southern Yellow Pine (also known as Southern Pine or Yellow Pine.) **DO NOT** use wood labeled as Spruce-Pine-Fir (or SPF). Four $\frac{3}{8}$ " [10 mm] masonry anchors can be used on concrete or block walls. If the wood splits once the torsion spring is in place, it should be replaced by a professional installer. **Do not try to remove or repair a torsion spring assembly or any red-colored fasteners once it is wound.**
- Springs, cables, and bottom fixtures are under strong spring tension. **Do not attempt to loosen any fasteners on these components.** You could suddenly release spring forces and risk severe injury.
- If the garage door and/or any of the supporting track are damaged, operating the door could be hazardous. Call an authorized representative of the manufacturer or professional door repair service promptly.
- **Do not permit children to play beneath or with any garage door or electric operating controls.**
- If repairs are ever required to your door, safety and trouble-free operation can be best assured by using original replacement parts.
- Once you have completed the installation of your new garage door, please be sure that your garage complies with all applicable ventilation requirements before you enclose any vehicles in the garage. Good ventilation avoids fire and health hazards caused by fumes accumulating within a well-sealed garage.
- Clopay Building Products Company disclaims all liability for any installation which is not in compliance with applicable state, county, or local building codes.
- Doors equipped with automatic door operators can cause serious injury or death if not properly adjusted and operated. To insure safe operation of these doors:
 - a) test the sensitivity of the operator's safety reverse mechanism monthly;
 - b) remove the pull rope;
 - c) make sure the door remains unlocked;
 - d) do not allow children to play with the controls.

Things to Know Before You Begin

Read the instructions completely before starting the installation of the door. Becoming familiar with the components before assembling the door will reduce the installation time.



In the interest of safety this symbol means WARNING or CAUTION. Personal injury and/or property damage may occur unless instructions are followed carefully.

- To avoid damage to the door, you must reinforce the top section of the door in order to provide a strengthened mounting point for attachment of an automatic opener (see page 29).
- Check headroom clearance requirements in the chart below before beginning.



WARNING

Springs and related hardware are under EXTREME spring tension and could cause SEVERE INJURY OR DEATH if mishandled. DO NOT ATTEMPT TO REPAIR OR ADJUST the springs, red fasteners, hardware, or structure to which they are attached.

Clearance Requirements

	Headroom ^{*,**,*}		Sideroom [*]		Backroom	
	2" [51 mm] Track	3" [76 mm] Track	2" [51 mm] Track	3" [76 mm] Track	2" [51 mm] Track	3" [76 mm] Track
12" [305 mm] Radius	14 1/2" [368 mm]	N/A	4 1/2" [114 mm]	5 1/2" [140 mm]	Door Ht.+23" [584 mm]	Door Ht.+25" [635 mm]
15" [381 mm] Radius	16" [406 mm]	18" [457 mm]	4 1/2" [114 mm]	5 1/2" [140 mm]	Door Ht.+23" [584 mm]	Door Ht.+25" [635 mm]
Low Headroom Rear Torsion	6 1/2" [165 mm]	10" [254 mm]	6" [152 mm]	6 1/2" [165 mm]	Door Ht.+30" [762 mm]	Door Ht.+32" [813 mm]
Low Headroom Front Torsion	10" [254 mm]	13" [330 mm]	6" [152 mm]	6 1/2" [165 mm]	Door Ht.+23" [584 mm]	Door Ht.+25" [635 mm]
High Lift	High Lift +12" [305 mm]	High Lift +12" [305 mm]	4 1/2" [114 mm]	5 1/2" [140 mm]	Varies	Varies
Vertical Lift	Dr. Ht. +12" [305 mm]	Dr. Ht. +12" [305 mm]	4 1/2" [114 mm]	5 1/2" [140 mm]	23" [584 mm]	25" [635 mm]

* Doors over 18' [549 cm] high, over 1,000 lbs. [454 kg] springing weight, high cycle springs, may require additional headroom and sideroom. Consult distributor for exact requirements.

* Doors with more than one row of springs require additional headroom.

** Chain hoist and electric operators require additional clearance. See instructions provided with operator for exact amount.

*** Vertical lift doors with straight incline require additional headroom. Contact factory.

IMPORTANT!

Before Starting Installation:

Step 1: Check the opening size and verify that the door is the proper size for the opening. Wood jambs require the door to be the same size as the opening with stop moldings nailed to inside of opening to seal the door. Steel jambs require the door to be two-inches wider than the opening to allow a one-inch door overlap on each side. No stop moldings are required in this application. The opening must be plumb and square to assure a good fit.

Step 2: Check all materials with the pick slip found in the hardware carton. Any report of shortages must be accompanied by the Clopay contract number. A copy of the pick slip is kept at the factory. Report the number of pieces received along with the number of pieces short. Springing information, including the number of turns to wind spring, can be found on the hardware box label.

Step 3: Check for sufficient headroom and side room. The chart below contains approximate clearance requirements. Headroom is the distance between the top of opening to the ceiling or the lowest obstruction.

Step 4: The hardware package supplied with your door should include red fasteners for attachment of the torsion spring center bracket and/or the bottom roller brackets. These fasteners must be securely attached as indicated in the installation manual.

Tools Needed

- “C” Clamps or Locking Pliers
- Hammer
- Winding Bars (Torsion Only)
- Screwdriver
- Tape Measure
- Level
- Socket wrench kit
- Pliers
- Drill, and $\frac{1}{4}$ " [6 mm], $\frac{3}{16}$ " [5 mm], & $\frac{3}{8}$ " [10 mm] bits
- Step ladder
- Saw horses or other supports for placing section on while assembling

Removing the Existing Door



WARNING

Garage doors use springs to balance the door weight. Generally there are two types of springs used — extension springs and torsion springs. **If your present door uses torsion springs, have a qualified door service professional remove them.** Attempting to remove a torsion spring assembly without proper training and tools may result in an uncontrolled release of spring forces which can cause serious or fatal injury.

Preparing the Opening

Step 1: On the inside of the garage your opening should be framed with wood jambs, 2" x 6" [51 mm x 152 mm] if possible, or with steel channel as shown in Figure 1-J. The side jambs should extend to approximately the same height as the headroom required. If you have just removed an old door, the condition of the jambs should be inspected. If the jamb has deteriorated, it should be replaced now. The jambs should be plumb and the header level. If there are any bolts fastening the jambs to the wall, the heads should be flush so they don't interfere with the installation of your new door. (FIG. 1-J) Typical installation for wood, steel or masonry jamb material is shown in Figure 2-J.

Step 2: Door stop molding for wood jambs should be temporarily nailed to the edges of the jambs flush with the inside. (FIG. 3-J) Since steel jambs require the door to be 2" [51 mm] wider than the opening, no stop molding is required. Stop molding featuring a built in weather seal is offered as an option.

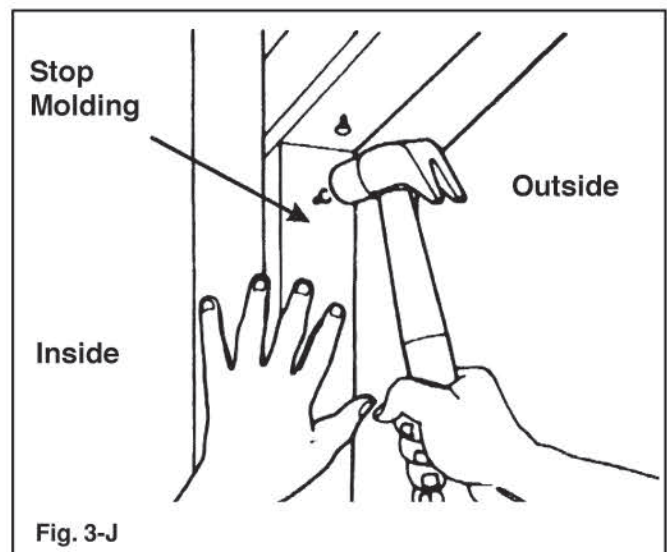
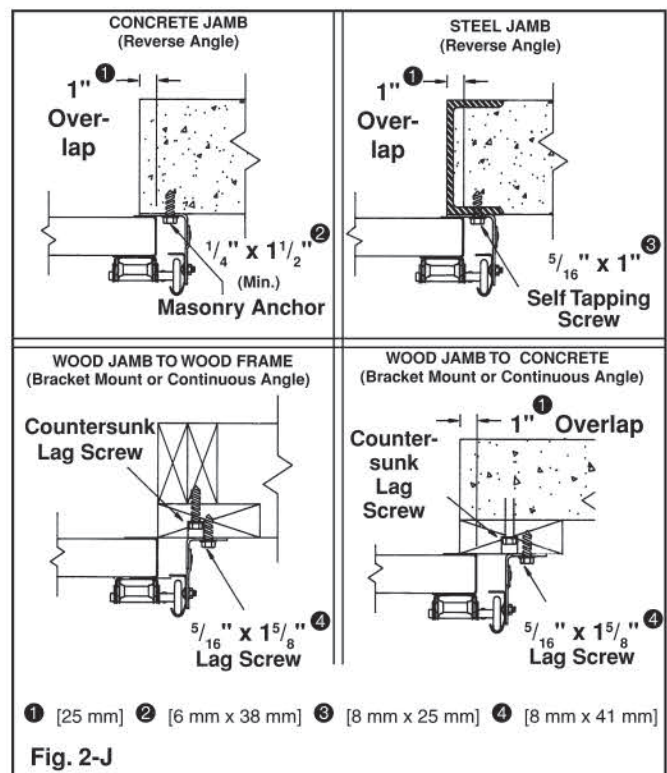
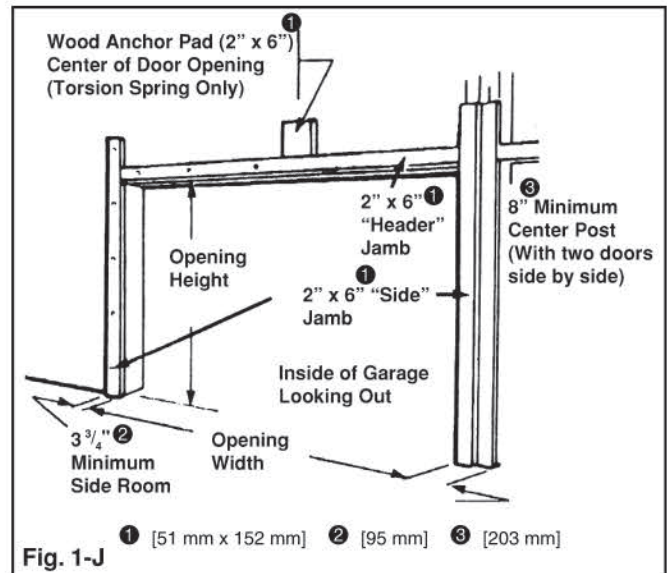

For Torsion Springs Only



WARNING

If your door has a torsion assembly, **you must make sure that the wood or steel anchor pad is of good quality, free of cracks or splits, and is firmly attached to the garage wall.** (Fig. 1-J) Failure to securely attach the anchor pad could allow the springs to violently pull away from the garage wall, and could result in severe injury and/or property damage. **Under no circumstances should the anchor pad be attached with nails.**

Refer to Figure 1-J & 2-J for the configuration of 2" x 6" [51 mm x 152 mm] wood jambs.

IMPORTANT: The wood anchor pad must be made of a Grade 2 or better Southern Yellow Pine (also known as Southern Pine or Yellow Pine) 2" x 6" x 12" [51 mm x 152 mm x 305 mm] minimum. The Southern Yellow Pine must be free of splits and cracks. **Do not use wood labeled as spruce-pine-fir (or SPF).** Steel anchor pads should be 1/4" x 10" x 12" [6 mm x 254 mm x 305 mm] minimum, securely fastened to the structure.

The wood anchor pad must be installed into the frame of the garage with at least four 3/8" x 3" [10 mm x 76 mm] long lag screws (one at each corner). The four lag screws must be installed no closer than 1 1/2" [38 mm] from the sides and the ends of the 2" x 6" [51 mm x 152 mm]. These lag screws must fasten into the structural frame of the building, not the drywall or sheet rock. Wood anchor pad and 3/8" x 3" [10 mm x 76 mm] lag screws are not supplied.

NOTE: The anchor pad can be off-center to the width of the opening by up to 10" [254 mm] in either direction.



WARNING

Red fasteners must be used for attachment of the bottom roller brackets on commercial doors.

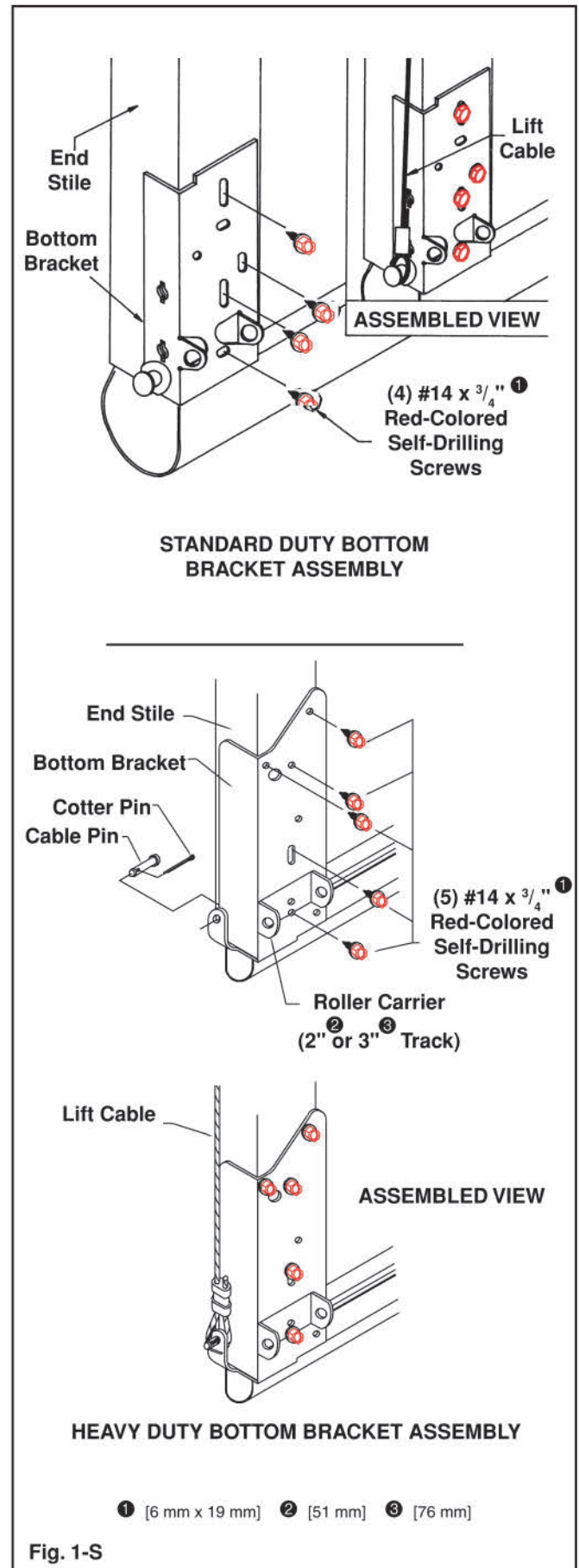
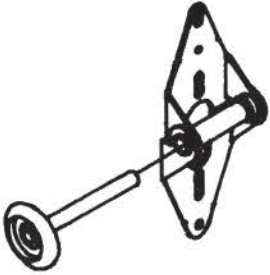

Fig. 1-S

HINGE ILLUSTRATION & ROLLER PLACEMENT

#1 Hinge

14 GA.



18 GA. Center Hinge



#2, 3, 4, Hinge

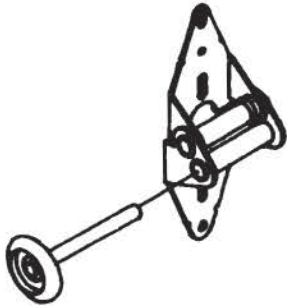

- All center hinges are #1 hinges (except for full vision sections, and Full View doors, see page 13).
- Start end hinge sequence at the top of bottom section.
- Double end hinges use the same # hinge as outside end hinges.
- **Rollers in end hinges will use farthest sleeve from section. (FIG. 2-S)**

	End Hinge Top of Each Section				
	Bottom Section	#2 Section	#3 Section	#4 Section	#5 Section
2" [51 mm] Track except as listed below	#1	#2	#3	#4	Continue in this manner
2" [51 mm] Track with Vertical or High Lift, (4) or (5) section high doors only	#2	#4	#6	#8	N/A
3" [76 mm] Track except as listed below	#4	#5	#6	#7	Continue in this manner
3" [76 mm] Track with Vertical or High Lift, (4) or (5) section high doors only	#4	#6	#8	#10	N/A

**SIDE VIEW
HINGES ARE TALLER WITH
INCREASING NUMBER**

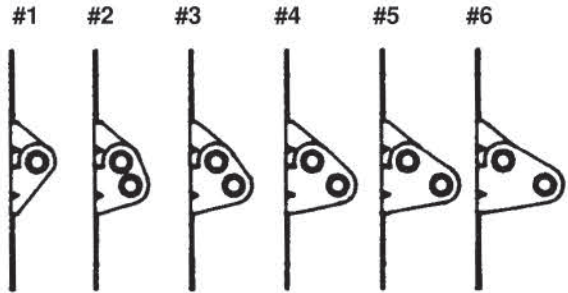

Fig. 2-S

Preparing and Installing Door Sections

Step 1: Bottom Section. Find bottom section (the one with bottom weatherseal), then lay it on saw horses. Find bottom bracket in hardware carton. Several different types are used depending on door thickness, door weight, and track size. Find the type of bottom bracket supplied in one of the pictures shown in Figure 1-S and fasten bottom bracket using the red-colored fasteners shown. (Low headroom doors refer to Figure 8-T, page 23.)

Some have flanges which hook under the bottom section and some do not. Install cables, then position the bracket in place. (FIG. 1-S) Install hinges on end and center stiles of the bottom section using #14 x 3/4" [6 mm x 19 mm] self-drilling screws. See Figure 2-S for sequence and hinge placement. For Model 901 doors and doors with Full Vision see page 13. Stack bottom section in opening. **Long stem rollers provided go into bottom brackets.** Install vertical track as described on page 15. Top rollers will hold section in place.

Strutting Schedule

NOTE: All doors do not require struts, follow instructions listed below according to the number of struts supplied.

- Number of struts will be shown on hardware box.
- All struts are attached with #14 x 3/4" [6 mm x 19 mm] self-drilling screws and struts to center stiles and end stiles.
- When only one strut is supplied it is to be mounted on the top section. (FIG. 3-S)
- When an equal number of struts and sections are supplied, install one on each section as illustrated, omitting strut with asterisk. (FIG. 3-S)
- If your door contains less struts than sections, evenly distribute the struts from bottom to top.

- Doors installed in high windload regions (Florida and other hurricane prone areas) may require additional reinforcement beyond what is detailed in these instructions. Please refer to engineering drawings for these areas.

- When there is one more strut provided than the number of sections this strut is to be mounted on the bottom section over the bottom bracket as shown in illustration. (FIG. 3-S)

- Top strut is to be mounted with top edge of strut 1/4" [6 mm] down from top of door and above top bracket as illustrated—except on low headroom installations, see page 23. (FIG. 3-S)

- With section face down on saw horses, place strut on top of section (section should be straight). Fasten strut at each end stile and each hinge hole location. Attach each end of the strut first, then attach center.

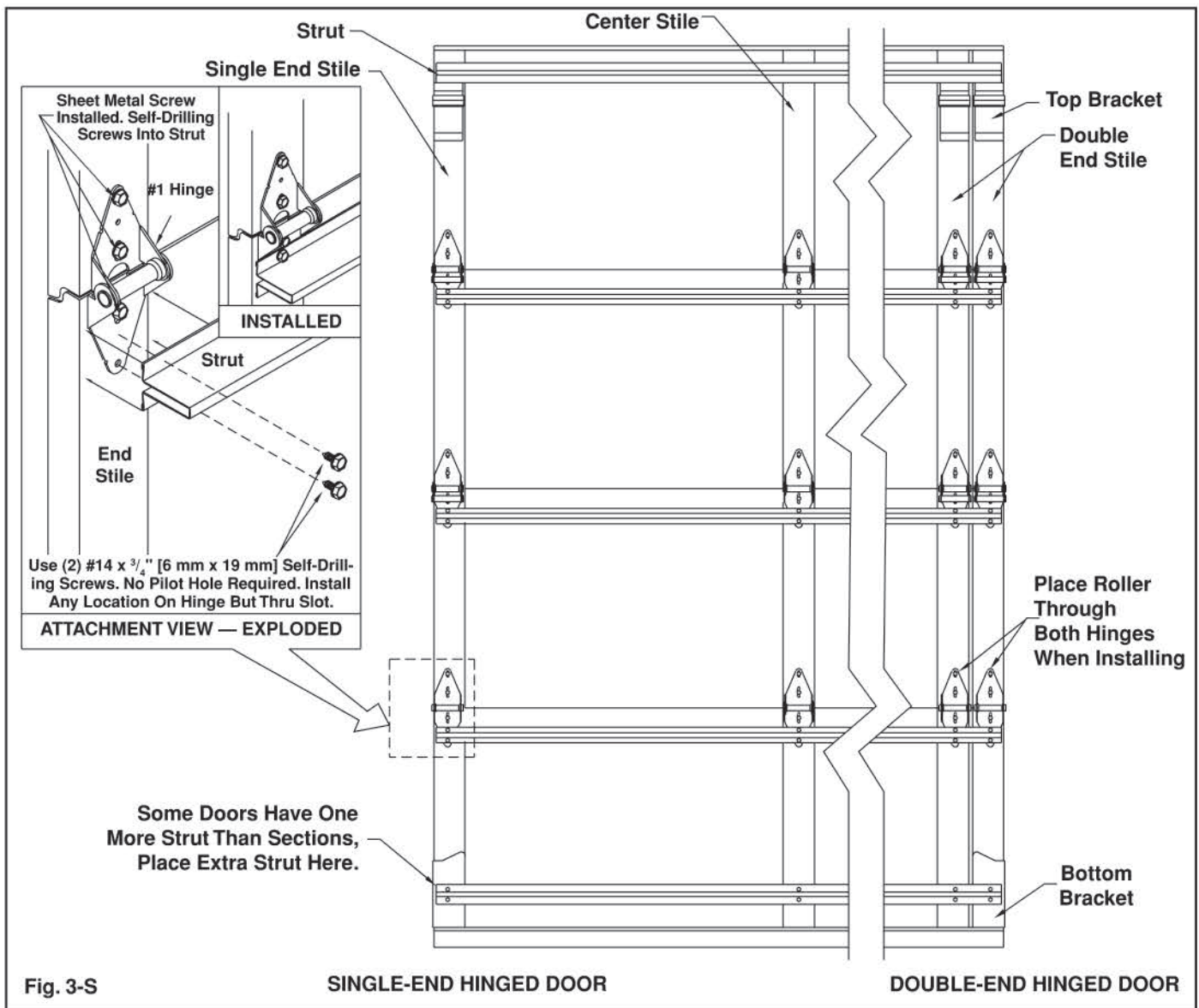

C-Channel Attachment (Non-Windload Doors Only)

If you have a windload door, refer to instructions or drawing provided with door.

Insulated Sandwich Doors Only

Before installation of hinges, tear the liner off the adhesive on the EPS backer plates and apply vertically across the section at each center hinge location. (FIG. 4-S)

All Doors

While Section is still on sawhorses, place C-Channel in the middle of section, with open end facing down. Using the access holes at each end of the C-Channel, attach (1) #14 x $\frac{3}{4}$ " [6 mm x 19 mm] self-drilling screw through the bottom of the C-Channel and into the Stile or EPS Backer Plate.

All Doors

Attach the C-Channel straps to the channel and the stile (or EPS backer plate), using (3) #14 x $\frac{3}{4}$ " [6 mm x 19 mm] self-drilling screws, at right. One strap is to go on each end of the channel, and a strap is to be placed at each center stile location.

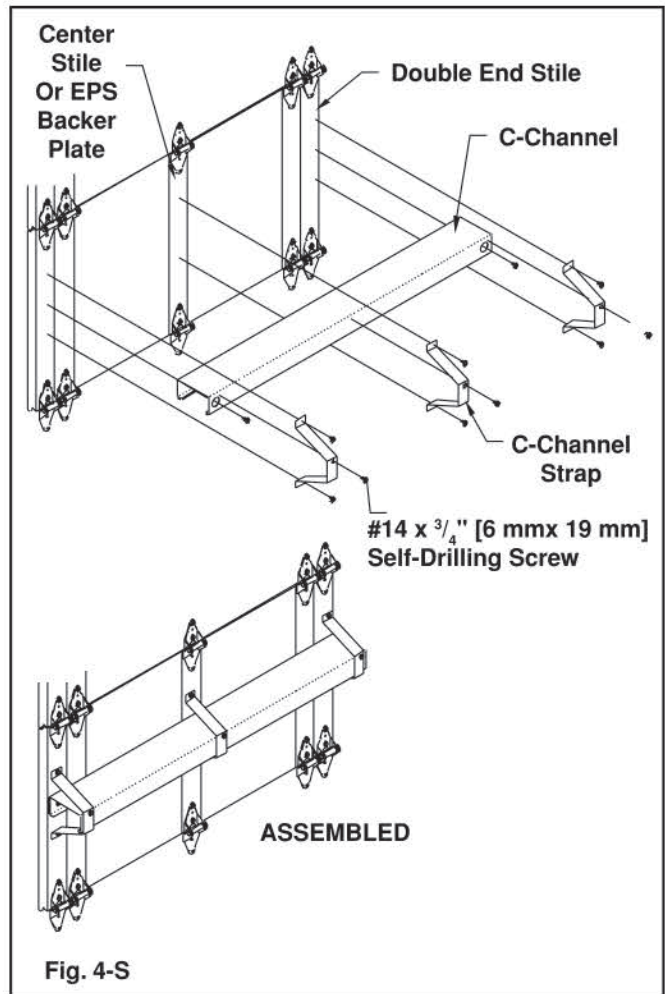

Lift Handle Instructions

Step 2:

If you have a 2" [51 mm] thick door, no modifications to the lift handle are necessary. If you have a nominal 2" [51 mm] thick door, remove the (4) tabs at the end of each stem using a pair of pliers. If you have a 1³/₈" [35 mm] thick door, cut the stems on the lift handle along the ridge line using a hacksaw. (FIG. 5-SA) From the front of the door section, drill (2) 1/2" [13 mm] holes through the section according to the Bottom Section Hole Pattern. (FIG. 6-S) A T-Square may be used to mark the holes to ensure that they are vertically in line. If your door has an outside keyed lock, the hole pattern should be drilled on the bottom section directly below the lock. If your door does not have an outside keyed lock, the hole pattern should be drilled directly below the hinge closest to the horizontal center of the door. Install the lift handle and inside step plate assembly using (2) #14 x 5/8" [6 mm x 16 mm] sheet metal screws. (FIG. 5-S)

IMPORTANT: Use a wrench or a socket to drive screws. Do not over tighten. Do not use an electric drill or driver.

NOTE: Plastic Lift Handles can be painted using a quality spray on or brushed on enamel paint.

NOTE: The Second Lift Handle should be located on the end stile underneath the lock location attached to the bottom bracket. (FIG. 7-S)

Section Seal. If section seal is provided or bought as an option, it should be installed over the inside ship lap or inside the groove as indicated in Figure 1-LAP and Figure 2-LAP.

Step 3:

#2 Section. Attach bottom half of center hinges to top of section using #14 x 5/8" [6 mm x 16 mm] hex head sheet metal screws. Attach end hinges. (FIG. 2-S) If section has lock see Step 4 for sequence. Stack section. After section is stacked, rollers in the track will hold section in place. (If struts are supplied see Figure 3-S for placement.)

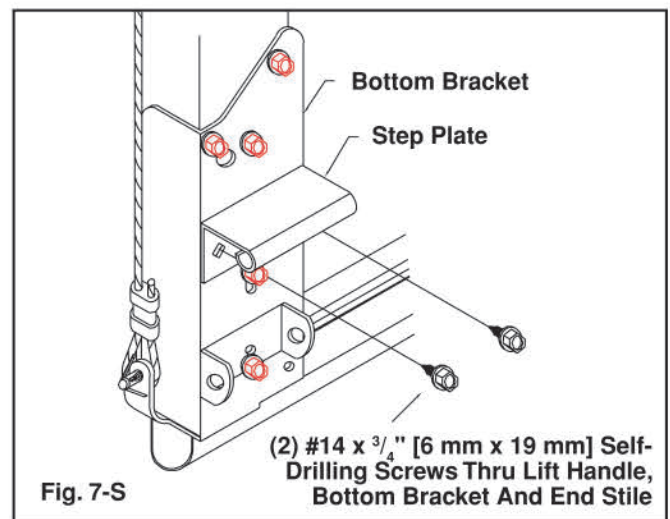
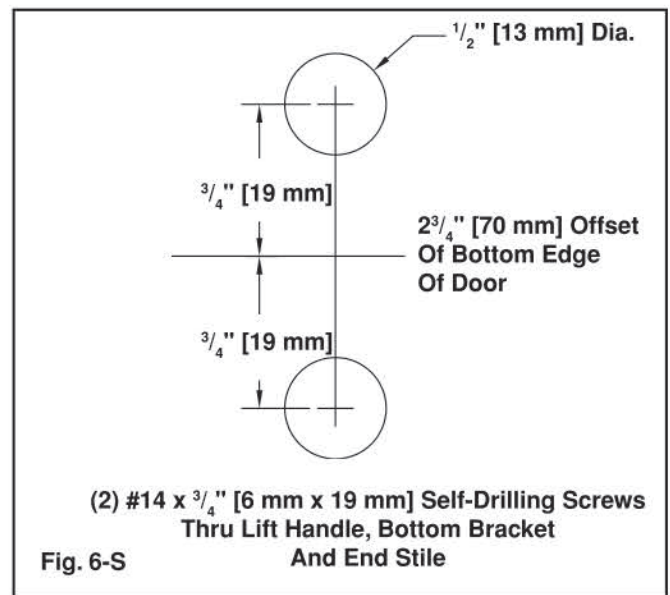
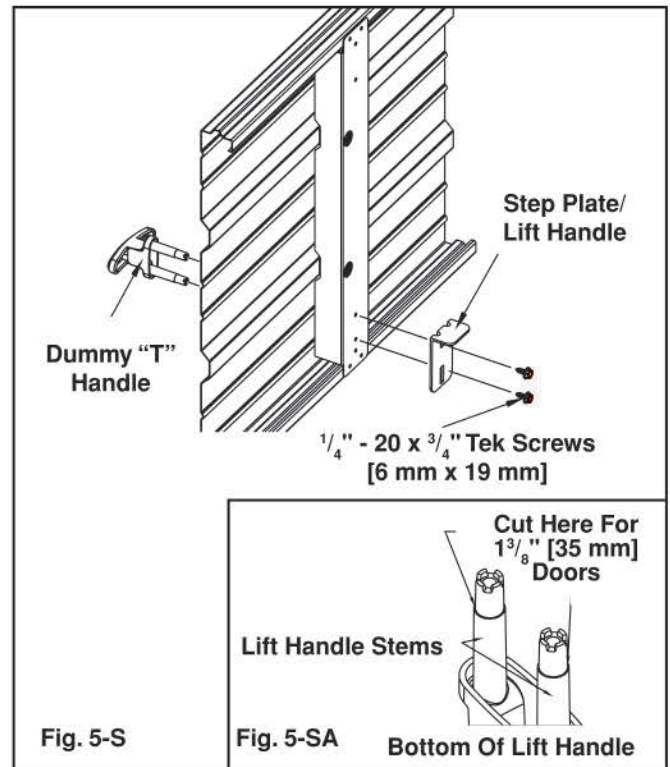
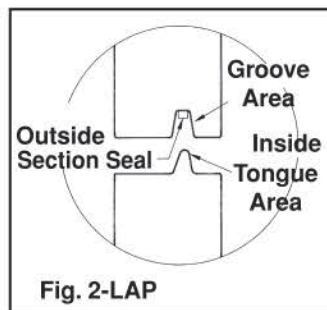
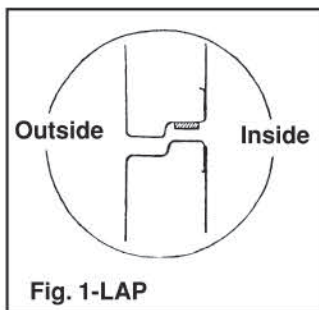

Lock Installation

Step 4: The following locking systems are available for commercial steel doors:

- Side Lock (FIG. 8-S)
- Inside Slide Bolt (FIG. 9-S)

1. Attach the side lock assembly to the second section. Unless otherwise specified, this stile will be located 18" [457 mm] in from the right hand side of the door (inside facing out). Secure the lock cylinder #2 with the two long machine screws as illustrated. Attach the handle (1) and inside lock mechanism (7), using the fasteners provided.

NOTE: 1³/₄" [44 mm] thick doors should use the 1³/₄" [44 mm] pan head machine screw (9) provided in the lock bag to mount the outside handle. 1³/₈" [35 mm] thick doors should use the 1¹/₂" [38 mm] pan head machine screw provided.

2. Finally, attach the lock bar (11) using 1¹/₄" - 20 x 1" [6 mm x 25 mm] hex head screw and nut (10 & 12), and lock bar guide (14) using #14 x 5/8" [6 mm x 16 mm] sheet metal screw. When track is permanently in place, adjust the lock bar guide so lock bar rests against the top of one of the engaging slots in the track. Details are shown in Figure 8-S.

3. The inside slide bolt is installed on the end stile of the second section so the slide bolt rests against the top of one of the rectangular engaging slots in the vertical track. Details are shown in Figure 9-S.

Step 5: #3 Section (and up to, but not including, top section). Attach bottom half of center hinges to top of section using #14 x 5/8" [6 mm x 16 mm] hex head sheet metal screw. Attach end hinges. (See Figure 2-S, page 8, for sequence.) After section is stacked, rollers in the track will hold section in place. (If struts are supplied see Figure 3-S, page 9, for placement.)

Step 6: Continue to stack and install remaining sections in the same manner as described in Step 5 until all but the top section are properly in place.

Step 7: Top Section. Place top brackets over pre-punched holes so they are flush with edge of section. Center of roller carrier will be about 4" [102 mm] down from top of section. Using four #14 x 5/8" [6 mm x 16 mm] hex head sheet metal screws per top bracket, attach top brackets to section. (FIG. 10-S) (Low headroom doors 3/4" [19 mm] refer to Figure 7-T, page 23.)

If struts are supplied see Figure 3-S, page 9, for placement.

Stack top section after all tracks are installed, but before springs are wound.

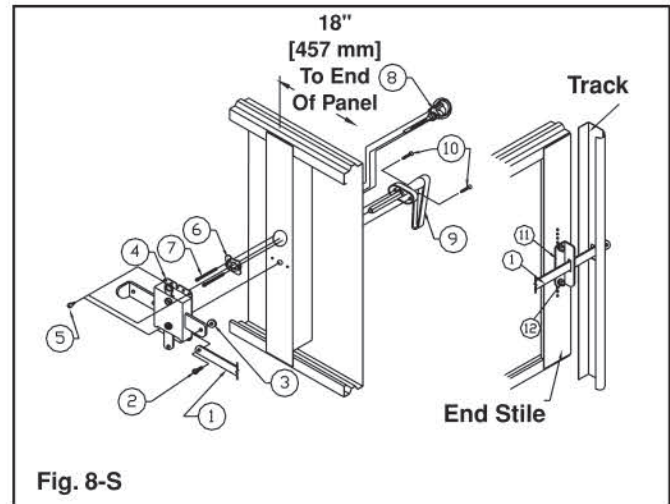

Fig. 8-S

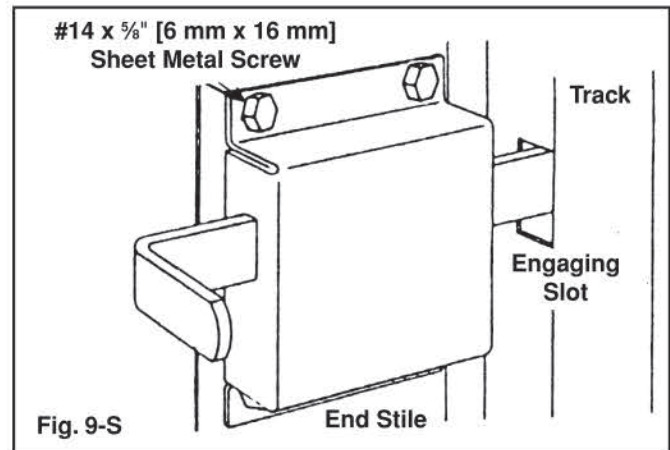

Fig. 9-S

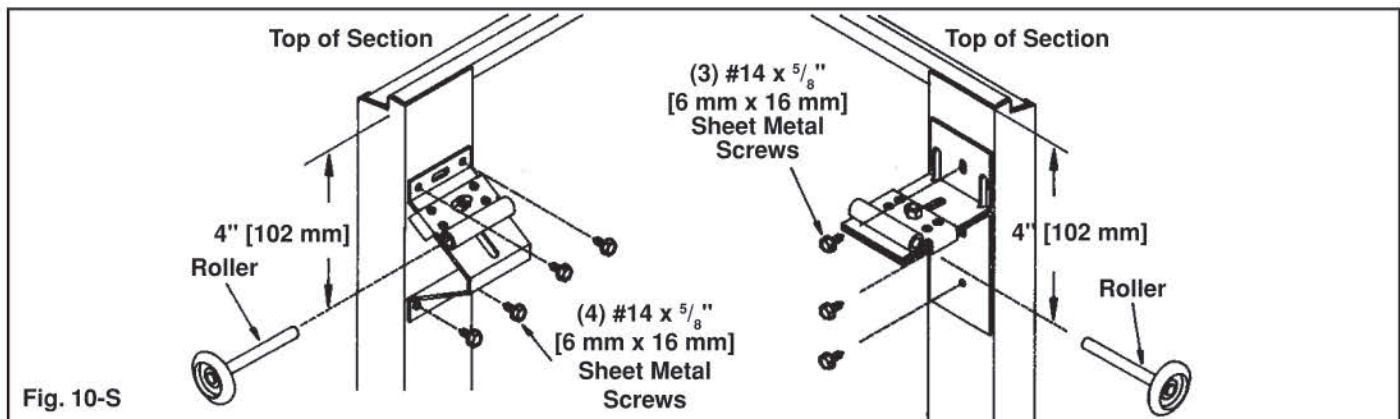

Fig. 10-S

Full Vision and Steel Door

If your door has been furnished with one or more full vision sections, please refer to Figure 11-S for identification of the special hinge parts which must be used.

End hinges are of the same type and follow the same sequence as described in the general instructions (refer to Figure 2-S, page 8). The standard #14 x $\frac{5}{8}$ " [6 mm x 16 mm] hex head sheet metal screws are used to fasten the end hinges to the full vision section. See Figure 12-S if you have a full vision top section.

For attachment of center hinges, proceed as follows:

Refer to the drawings in Figure 11-S for identification of proper center hinges and the positions in which they are to be installed. Note that the #14 x $\frac{3}{4}$ " [6 mm x 19 mm] self-drilling screws are used in the bottom rails and the $\frac{1}{4}$ " x $\frac{3}{4}$ " [6 mm x 19 mm] hex bolts and $\frac{1}{4}$ " [6 mm] hex nuts are used to attach the center hinge to the fin of the upper rail. (FIG. 12-S) Special attention must be given to this step of the procedure since proper placement of hinges is critical to installation of the door.

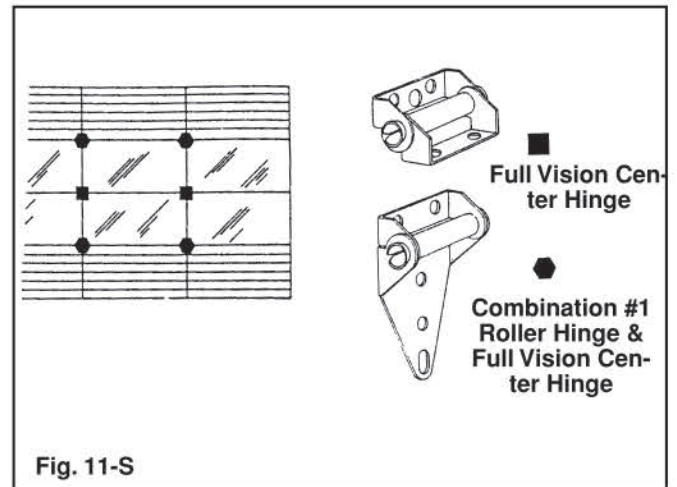
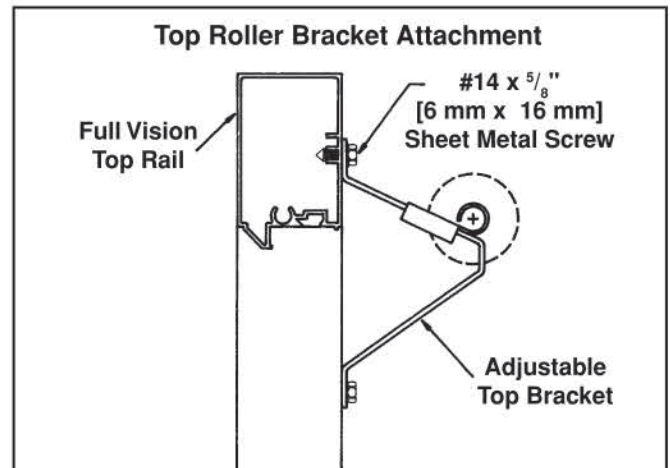

Fig. 11-S



If your door has a full vision top section, it is very important that each top roller bracket be attached to the reinforcing fins in the top rail and the end stile. Two #14 x $\frac{3}{4}$ " [6 mm x 19 mm] self-drilling screws should fasten the top of each bracket to the top rail and one screw should attach the bottom of the roller bracket to the end stile.

Remember: the small indentations that run the length of the top rail and end stile mark where the reinforcing fins are located.

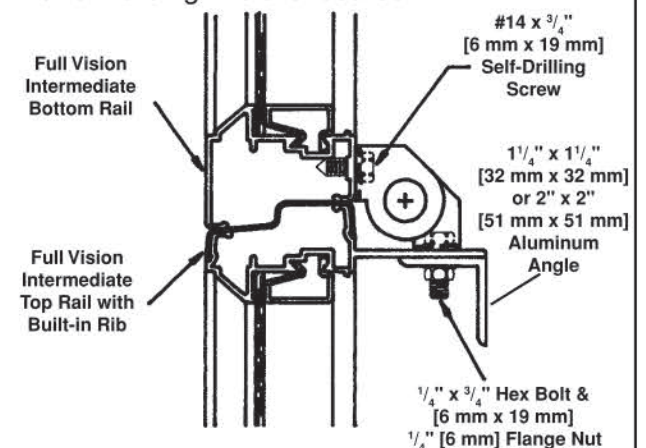

Fig. 12-S

Refer to Figures 12-S, 13-S and 14-S for reinforcement of full vision sections. After full vision sections are in place, refer to the general instructions for completion of your installation.

Sometimes, higher than standard wind loading requires a bridge strut (aluminum angle with offset plates). (FIG. 14-S)

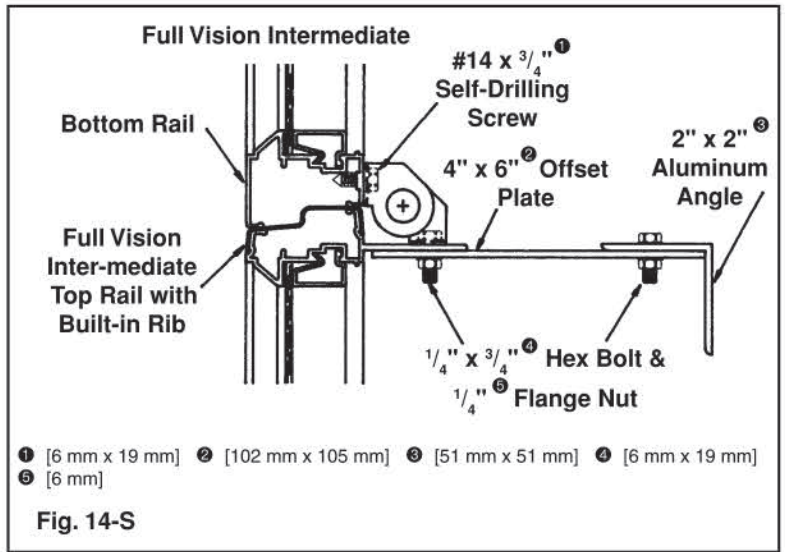

Fig. 14-S

REINFORCEMENT SCHEDULE	
Door Width	What Is Needed For 1/8" [3 mm] Thick Glazing
Up to 11'2" [340 cm]	None
11'4" to 12'2" [345 cm to 371 cm]	None
12'3" to 14'2" [373 cm to 432 cm]	One 1 1/4" x 1 1/4" x 1/8" angle per section [32 mm x 32 mm x 3 mm]
14'3" to 15'2" [442 cm to 462 cm]	One 1 1/4" x 1 1/4" x 1/8" angle per section [32 mm x 32 mm x 3 mm]
15'3" to 16'2" [465 cm to 493 cm]	One 1 1/4" x 1 1/4" x 1/8" angle per section [32 mm x 32 mm x 3 mm]
16'3" to 18'2" [495 cm to 554 cm]	One 2" x 2" x 1/8" angle per section [51 mm x 51 mm x 3 mm]
18'3" to 20'2" [556 cm to 615 cm]	One 2" x 2" x 1/8" angle per section [51 mm x 51 mm x 3 mm]
20'3" and Over [617 cm]	One Bridge Strut per section
Door Width	What Is Needed For 1/4" [6 mm] Thick Glazing
Up to 11'2" [340 cm]	None
11'4" to 12'2" [345 cm to 371 cm]	One 1 1/4" x 1 1/4" x 1/8" angle per section [32 mm x 32 mm x 3 mm]
12'3" to 14'2" [373 cm to 432 cm]	One 1 1/4" x 1 1/4" x 1/8" angle per section [32 mm x 32 mm x 3 mm]
14'3" to 15'2" [442 cm to 462 cm]	One 2" x 2" x 1/8" angle per section [51 mm x 51 mm x 3 mm]
15'3" to 16'2" [465 cm to 493 cm]	One 2" x 2" x 1/8" angle per section [51 mm x 51 mm x 3 mm]
16'3" to 18'2" [495 cm to 554 cm]	One Bridge Strut per section
18'3" to 20'2" [556 cm to 615 cm]	One Bridge Strut per section
20'3" and Over [617 cm]	One Bridge Strut per section

Fig. 13-S

Track Installation

General Information. There are three basic pieces of information about your tracks that you need to know to start installation.

1. Track size - Track comes in two sizes: 2" [51 mm] and 3" [76 mm].

2. Type of lift - Each type of lift is different from the top of the door on up. However, the vertical track from the floor to the top of the door does not change between the different lift options. (FIG. 1-T) Therefore, the vertical track instructions to the top of the door are explained in one group (Step 1). Then turn to your specific type of lift for completion of the installation.

3. Type of mounting - Bracket mounting is used on lighter doors with wood jambs. Brackets are loose or riveted into place. Loose brackets are attached to the track with (1) $\frac{1}{4}$ " x $\frac{5}{8}$ " [6 mm x 16 mm] track bolt and nut per bracket. Continuous angle and reverse angle track are shipped with mounting angle attached. Loosen nuts on track bolts so track will slide on the angle. (FIG.1-T)

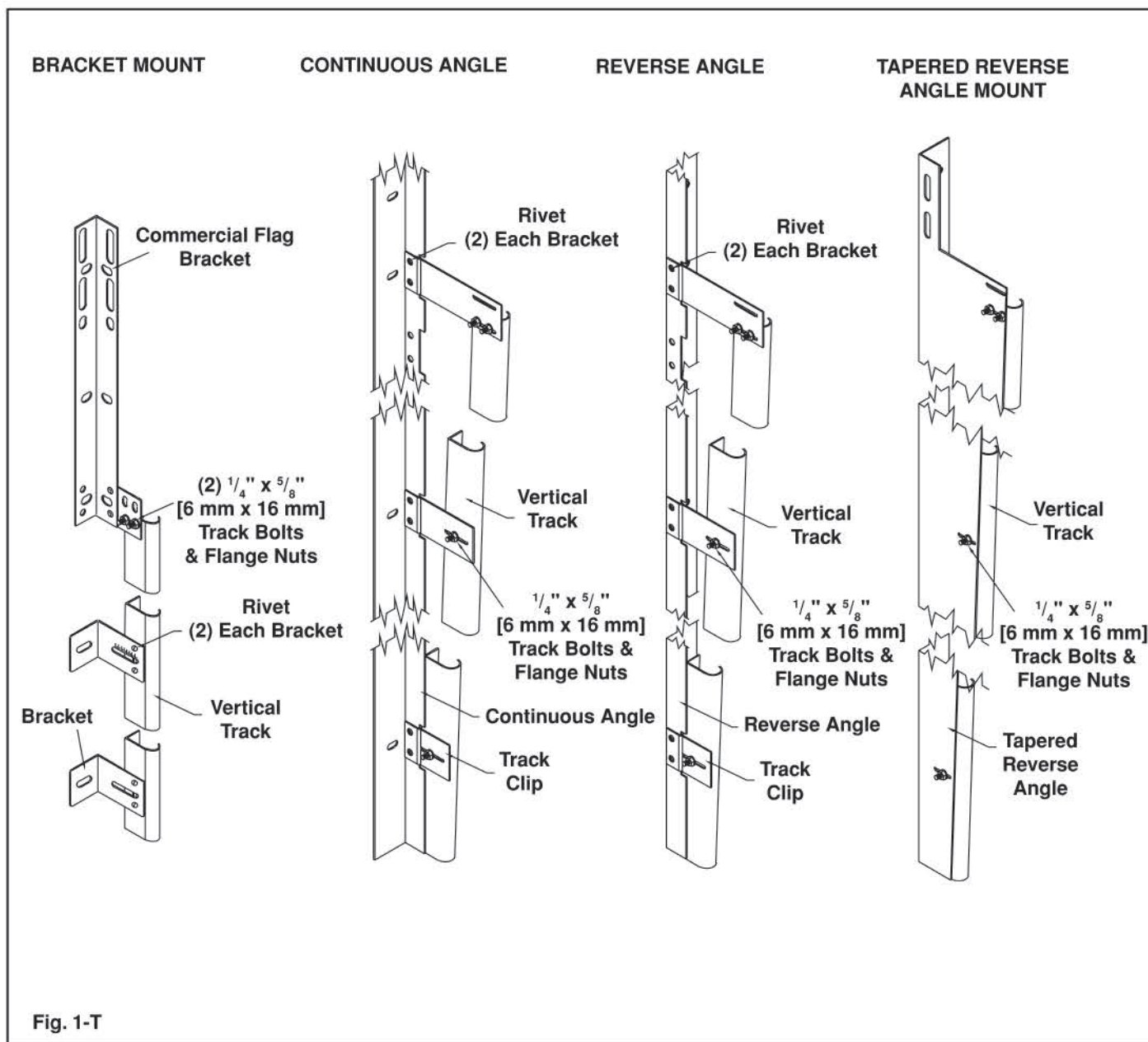

Fig. 1-T

Step 1: Vertical Track. Center bottom section in opening on inside of garage. Level section by blocking up low side. (FIG. 2-T) Leave block until door is completed. Install the vertical track on opposite side of where block was placed, over the two rollers of the bottom section with a twisting motion as in Figure 3-T. Raise track $\frac{1}{2}$ " [13 mm] off the floor, Figure 2-T, and screw $\frac{5}{16}$ " x $1\frac{5}{8}$ " [8 mm x 41 mm] lags (wood jambs), or self-drilling screws (steel jambs) through bottom mounting bracket. (FIG. 4-T) Adjust track sideways to allow $\frac{1}{8}$ " [3 mm] end play in roller—about $\frac{1}{4}$ " [6 mm] from edge of track to edge of door. (FIG. 2-T) Plum vertical track and put at least two lags or sheet metal screws in the mounting brackets at the top of the door. Final adjustment will be made after door is stacked. Measure from the top of the vertical track to the top of the bottom section and set the opposite track at exact same height repeating above procedure. (FIG. 2-T) Since the bottom section is level, then the vertical tracks must be level. **Make sure bottom rollers do not come out of the bottom of the track.**

Step 2: Stacking. Stack #2 section on top of bottom section and attach end hinges with rollers in track to hold section in place. Stack the rest of the sections except the top (the top section must be installed after all the tracks are up).

Swing up top half of hinges and use #14 x $\frac{5}{8}$ " [6 mm x 16 mm] hex head sheet metal screws to fasten door.

Step 3: Finishing Vertical Track. Set the top of the vertical tracks so that there is $\frac{1}{4}$ " [6 mm] end play in the rollers, about $\frac{1}{2}$ " [13 mm] from edge of track to edge of door. (FIG. 2-T) Finish attaching vertical track to the wall. If you are mounting on steel jambs, you will have to wait until you can raise the door to finish attaching vertical tracks.

NOTE: To complete the rest of the track installation, refer to the page explaining your specific lift option:

- Standard RadiusPage 17
- Roof PitchPage 23
- Low Headroom Rear Mount.....Page 24
- Low Headroom Front MountPage 26
- Vertical LiftPage 27
- High Lift.....Page 28

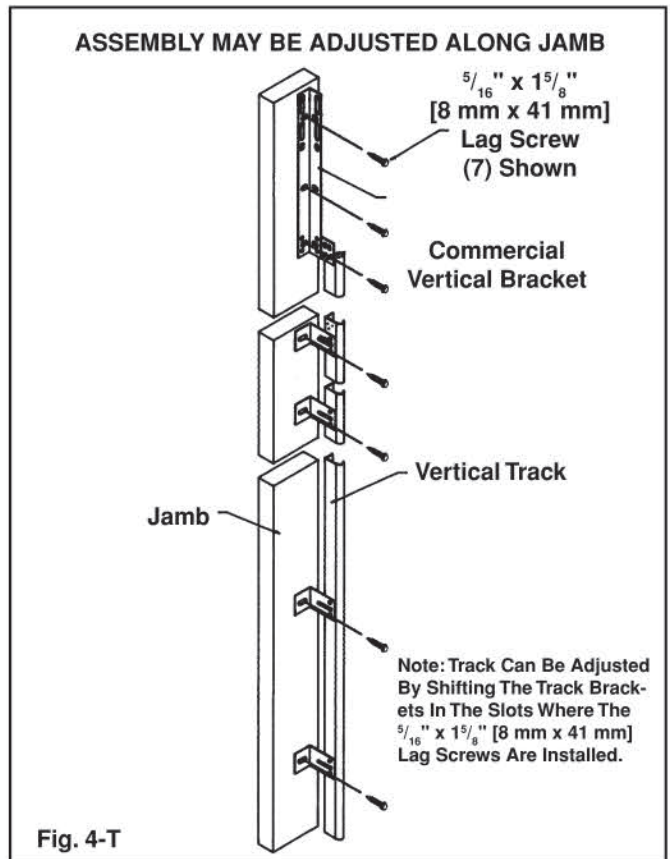
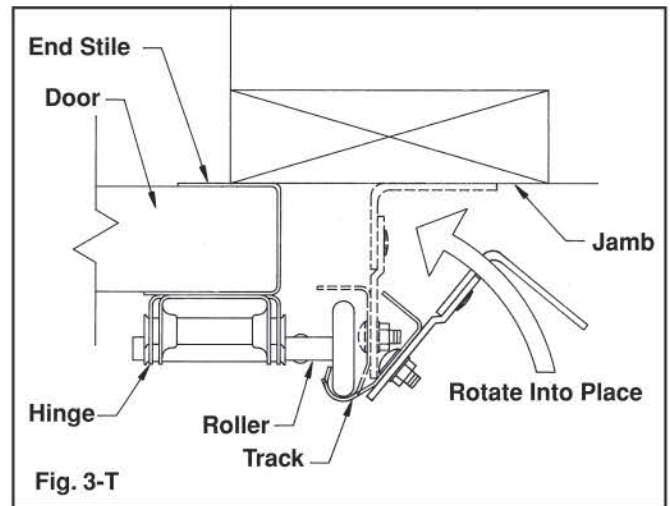
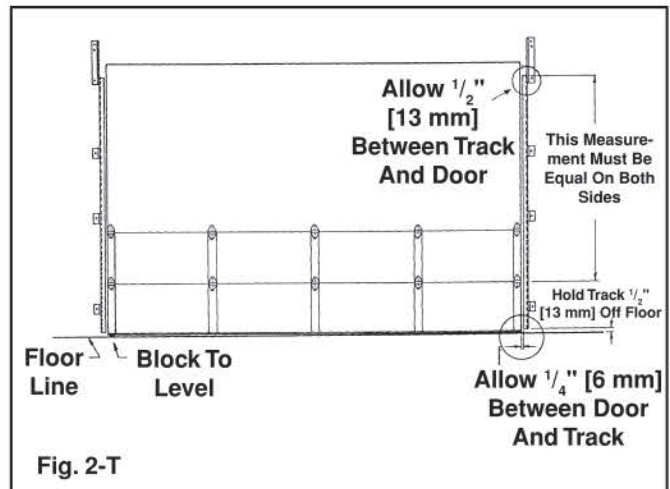

Standard Radius

Attach horizontal track to vertical bracket using $\frac{1}{4}$ " x $\frac{5}{8}$ " [6 mm x 16 mm] track bolts and flange nuts. Attach horizontal angle to vertical bracket using $\frac{3}{8}$ " x $\frac{3}{4}$ " [10 mm x 19 mm] carriage bolts and flange nuts. Rig a temporary rope to support back of horizontal tracks. They should be level (parallel) to 1" [25 mm] higher in the back when completed. Install top section now to other sections. Refer to Figure 9-S, page 12. (FIG. 5-T)

Spring Installation (Page 18)

Install and wind springs as explained. After springs are installed and wound, release locking pliers and raise door **so that only the two top sections** are in the horizontal tracks. Secure door in place with locking pliers on track above a roller, making sure it can't be raised, and align horizontal tracks. Backhang doors. (FIG. 5-T) **Any door over 12' [366 cm] high requires two backhangs on each horizontal track.** See important note at top of this page for backhang requirements. All backhang material is supplied by the installer. See backhang requirements.

Lower door and push track towards jambs until door is tight against stop or steel jambs and tighten track bolts. Adjust top brackets. (Figure 9-S, page 12) Install inside side slide lock or lock bar (Figure 7-S & 8-S, page 12) after spring is wound. Nail door stop in place if applicable.

IMPORTANT: Backhang Requirements

Important Note: All doors over 12' [366 cm] high require two backhangs evenly spaced on each horizontal track. (FIG. 5-T) Also, all low headroom track doors, all doors 12' [366 cm] high and under that are over 600 lbs. [272 kg] or have 1" [25 mm] of sag in horizontal track when the door is in full open position, will require two backhangs evenly spaced on each horizontal track.

Inspection of horizontal track is required after completion of garage door installation. With the garage door in the full open position, there should only be $\frac{1}{4}$ " [6 mm] of freeplay in rollers and $\frac{1}{2}$ " [13 mm] from the edge of the horizontal track to the edge of the door. (FIG. 5-T) Realign tracks if necessary.

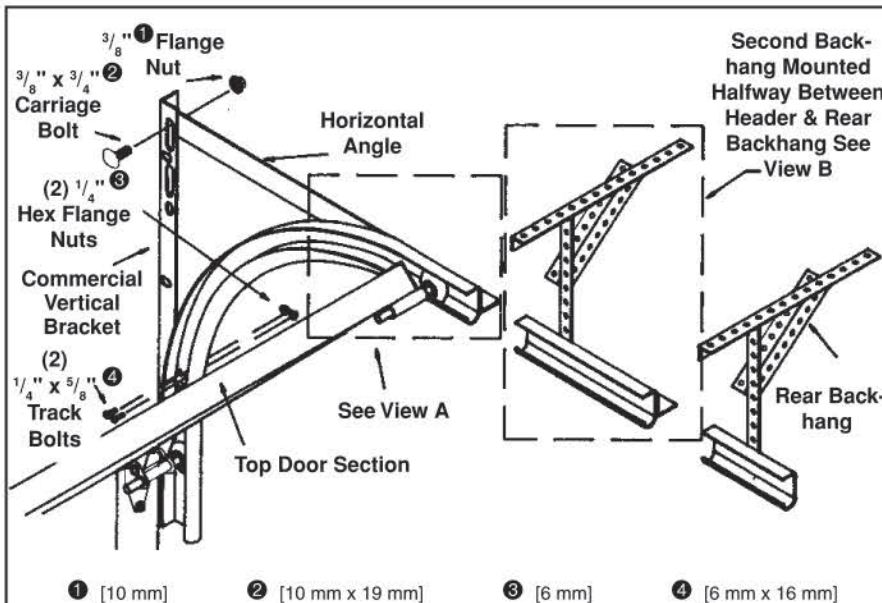
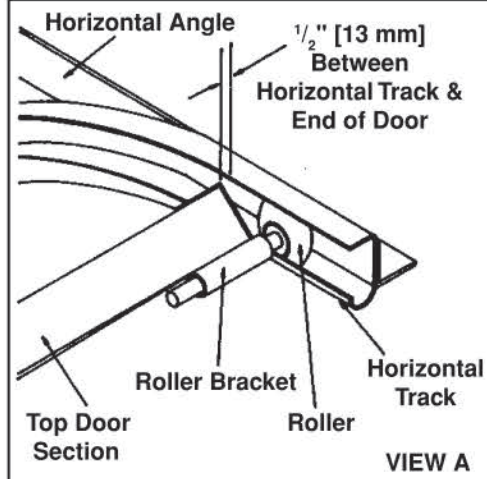
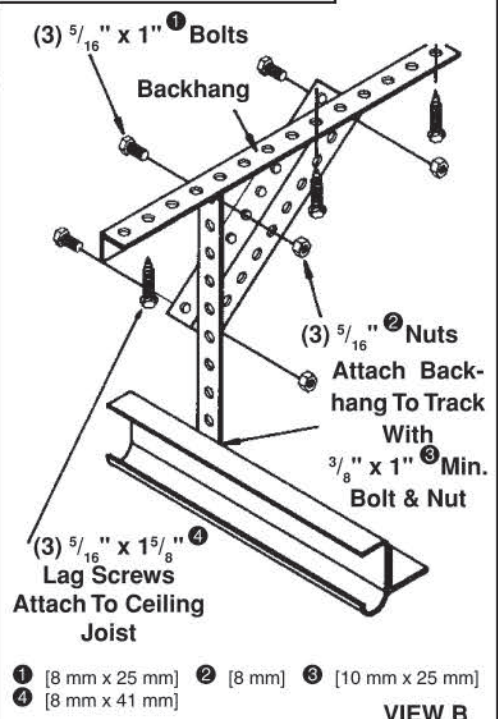

Fig. 5-T



VIEW B

Spring Installation

NOTE: All torsion spring doors will be furnished with a Red Warning Label. These labels must be on all spring anchor brackets in plain view. These Warning Labels will be supplied on spring anchor brackets or in the hardware carton. If sticker is missing it is the responsibility of the installer to contact his supplier and have them provide needed warning labels for installation.

Spring anchor bracket mounting location.

Measure from top of door to center of end bearings. Using this measurement, draw a line at the same height for shaft location and mount spring anchor bracket accordingly.

Torque Tube Installation

Slide drums on tube and loosen all set screws. Slide tube into one end bearing plate then back through the opposite one. **Fasten spring anchor bracket using $\frac{5}{16}$ " x $1\frac{5}{8}$ " [16 mm x 41 mm] red-colored lags.** See warning below. Tube must be straight and level. (FIG. 1-TOR)

NOTE: Pilot drill in wood with $\frac{3}{16}$ " [5 mm] drill.



WARNING

Spring anchor brackets anchor the springs to the wall. You must fasten securely with red-colored fasteners. Never remove spring anchor bracket when springs are wound.

Always start with the left drum. Slide it against the end bearing plate and tighten set screws.

Set screws: Tighten set screws enough to dimple shaft, about $1\frac{1}{4}$ turns after set screws first hit shaft. Make sure set screws are placed 90 degrees apart.

(FIG. 1-TOR) Bring cable up between wall and roller shafts behind drum and into notch in edge of drum. Turn drum and shaft until cable is tight. Make sure cable stop is seated against drum. Clamp locking pliers on shaft and against header to hold cable tight. Wind cable on right drum and tighten set screws. Tension must be equal on both cables. Cables are now set. See spring winding directions. (FIG. 1-TOR)

Auxiliary Shaft Supports

Refer to Figure 1-AT for placement of auxiliary shaft supports if required.

Solid Shaft Installation

Slide drums on shaft and loosen all set screws. Install shaft coupler. Insert key and tighten set screw.

Set screws: Do not exceed $\frac{1}{2}$ turn after coming in contact with shaft. Make sure set screws are placed 90 degrees apart.

(FIG. 2-TOR, View F) Slide either shaft into end bearing and **fasten spring anchor bracket using $\frac{5}{16}$ " x $1\frac{5}{8}$ " [8 mm x 41 mm] red-colored lag screws (wood jambs) $\frac{5}{16}$ " x 1" [8mm x 25 mm] red-colored self-tapping screws (steel jambs).** Center shaft on the mark made earlier for proper height. Slide other shaft into opposite side and align shaft coupler. Clamp shaft coupler together and fasten spring anchor brackets. Slide both drums against end bearings and insert $\frac{1}{4}$ " x $\frac{1}{4}$ " [6 mm x 6 mm] keys and then tighten set screws. (FIG. 2-TOR, View E) Remove locking pliers from shaft coupler.

Bring cable up between wall and roller shafts, behind drum and into notch in edge of drum. Turn drum and shaft until cable is tight. Make sure cable stop is seated against drum.

Clamp locking pliers onto shaft and against header to hold cable tight. Repeat procedure for setting cable on the opposite side. Tension must be equal on both cables. Bolt shaft coupler together. Cables are now set. See spring winding directions following.

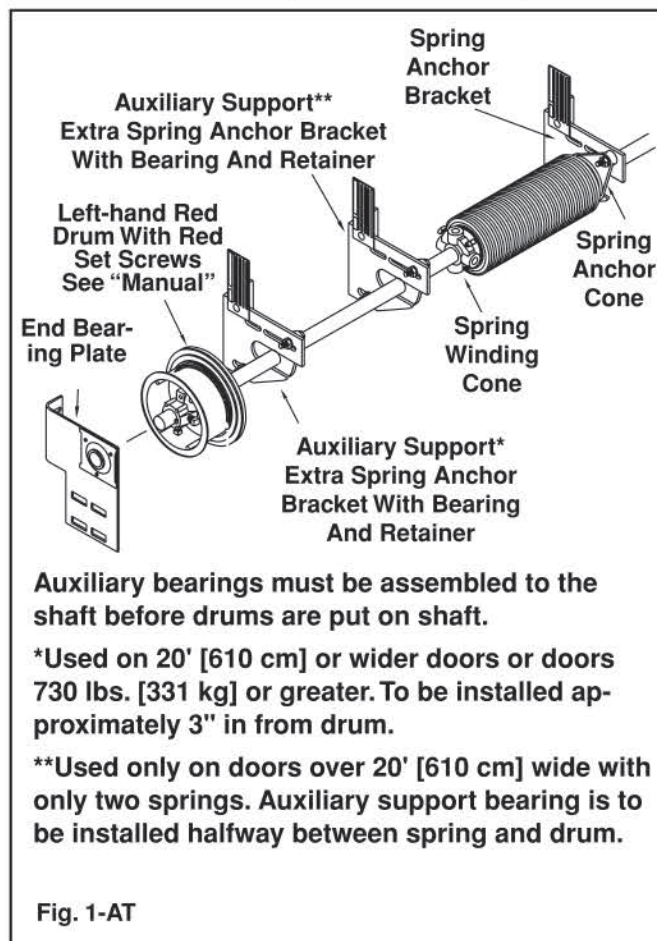

Fig. 1-AT

Spring Winding



WARNING

SPRING TENSION IS DANGEROUS.

A sudden release of the springs could result in severe injury. Proceed with caution, following these instructions carefully. Before winding any tension on springs, make sure door is securely locked down with a vise-grip placed on vertical track above a roller. Always use proper size winding bars. Never use screwdrivers or any tool too large or too small. They may break and cause serious injury. Stand to the side of winding bars while winding springs.

Draw a straight chalk line across spring. This will indicate the number of turns on spring as you wind. Springs will get longer when wound. Using two cold rolled steel winding bars about 18" [457 mm] long (not supplied) that fit snugly in the winding plug holes, wind the springs toward ceiling as shown. (FIG. 1-TOR & 3-TOR) **Low head-room double track doors: wind springs toward the floor (down) instead of up.** See instructions on pages 23 & 24. Wind springs the number of turns shown on the hardware box label. **Stretch the springs the width of two coils then tighten set screws.** This is done by putting the two winding bars on opposite sides of the winding plug and pulling towards drum.



WARNING

At this point, springs are fully wound. Springs should stretch easily. Do not force, as it could break the winding plug and cause injury.

Set Screws

Torque Tube: Tighten set screws enough to dimple shaft, about $1\frac{1}{4}$ turns after set screws first hit shaft.

Solid Shaft: Do not exceed $\frac{1}{2}$ turn after coming in contact with shaft.

To finish door installation, refer to your specific type of track. Final spring tension adjustments should be made after installation is completed. Always adjust springs with door closed and locked.

**ONE SPRING ON STEEL TUBE
LEFT WOUND SPRING SHOWN**

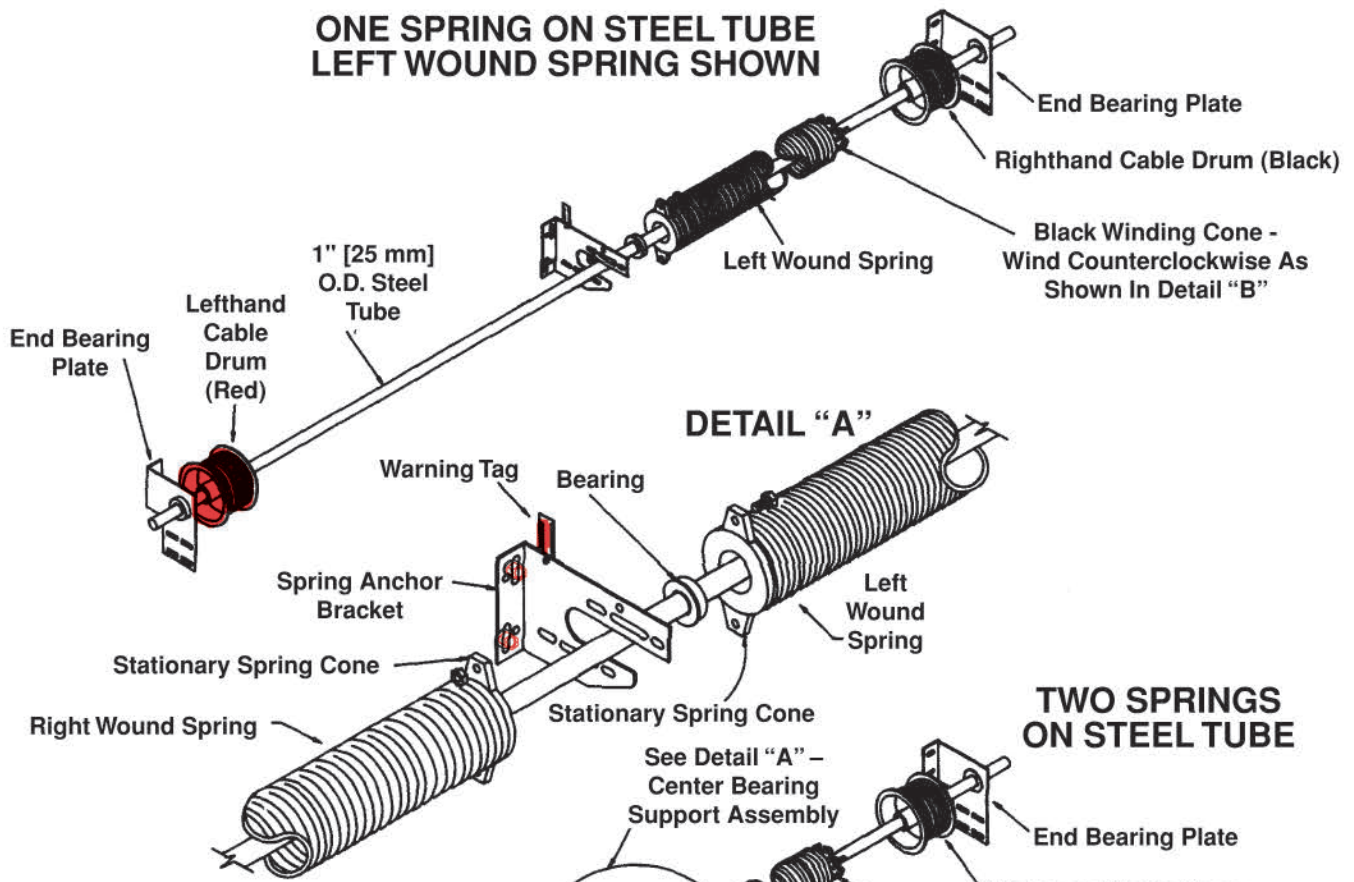

DETAIL "A"

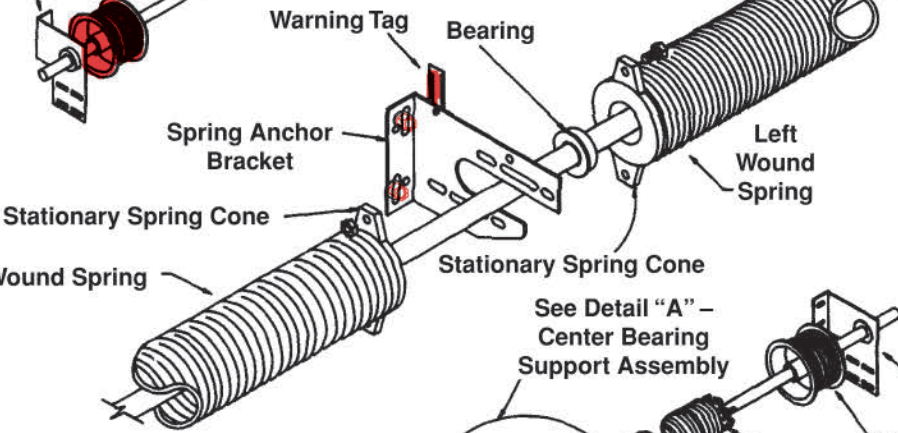

TWO SPRINGS ON STEEL TUBE

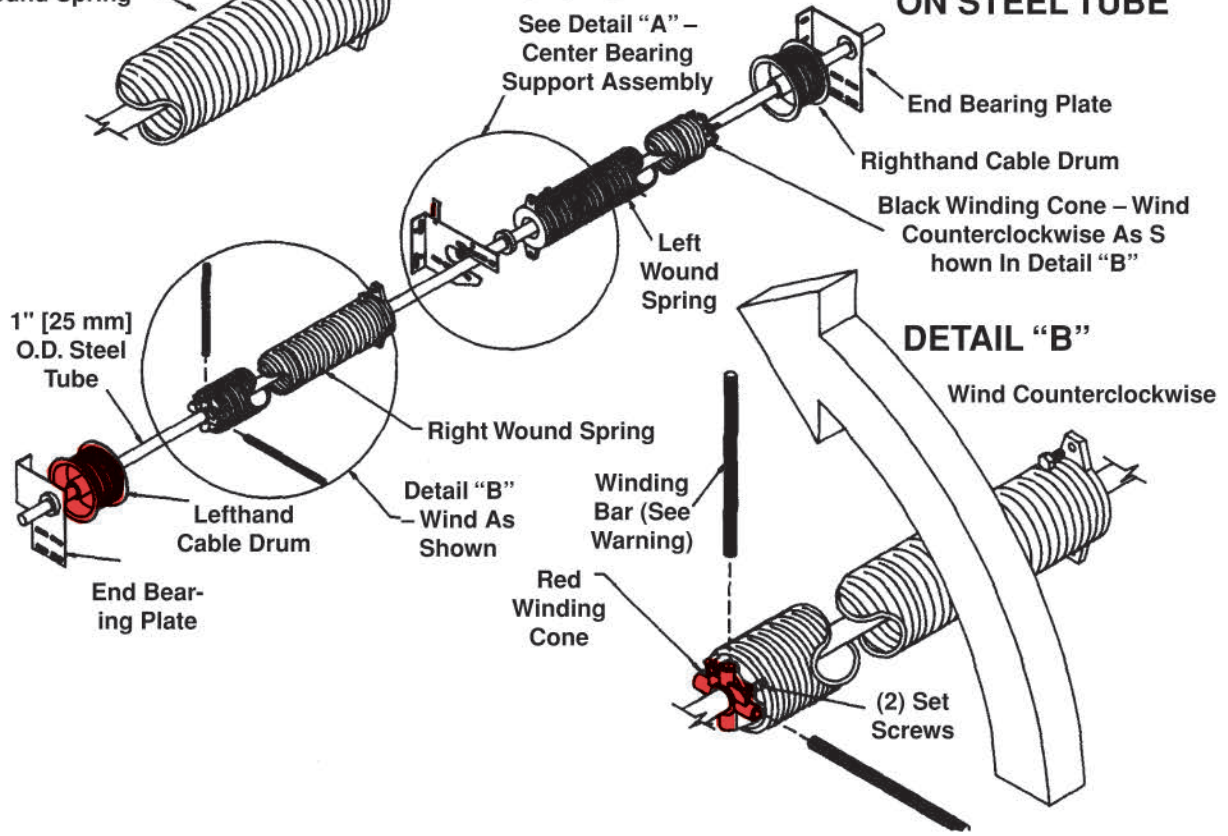

DETAIL "B"

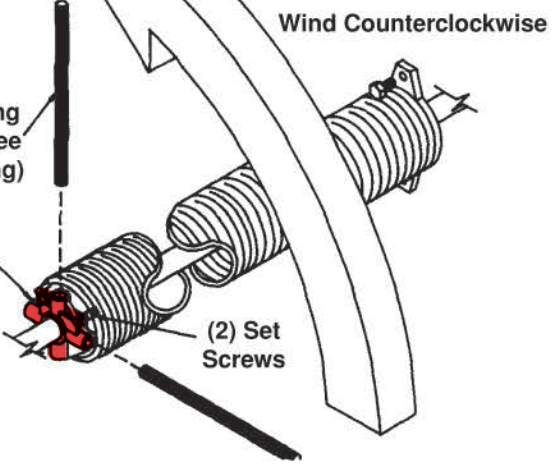

⚠ WARNING ⚠

Always use good quality, snug fitting, constant diameter, solid steel winding bars when winding or adjusting springs. The use of any other object can result in severe injury. When winding the springs, the winding bar must be inserted into the full depth of the holes in the winding cone. Keep a firm grip on the winding bars at all times. Use a sturdy ladder and stand to the side of the winding bars.

If your door has a torsion spring assembly, you must make sure that the wood anchor pad is firmly attached to the garage wall. Failure to securely attach the anchor pad could allow the springs to violently pull away from the garage wall, and could result in severe injury and/or property damage. In no case should nails be used.

Fig. 1-TOR

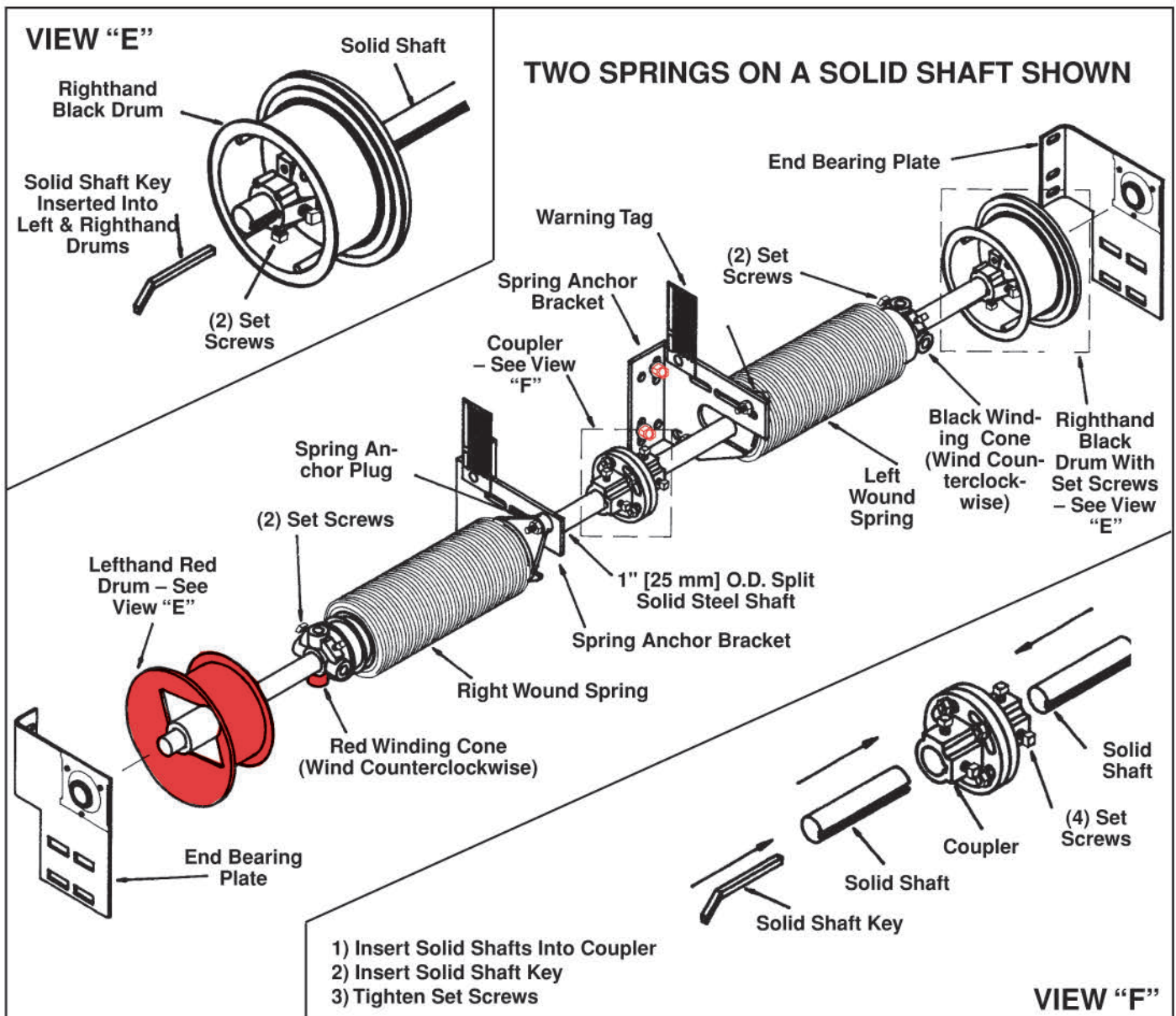

HEAVY DUTY BEARING MOUNTING SYSTEM
 (Used for special applications)

Step 1: Attach heavy duty bearing to end bearing plate with (4) $\frac{3}{8}$ " [10 mm] bolt and nut—making sure that bolt head is toward cable drum as shown in diagram.

Step 2: Slide cable drum, then spacer, and then bearing plate (with attached bearing) onto the shaft.

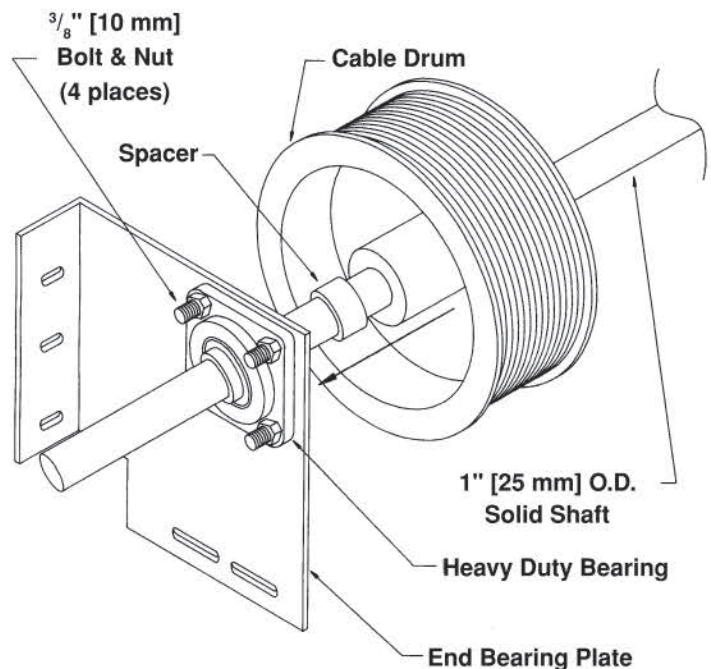

Fig. 2-TOR

FOUR SPRINGS ON SOLID STEEL SHAFT

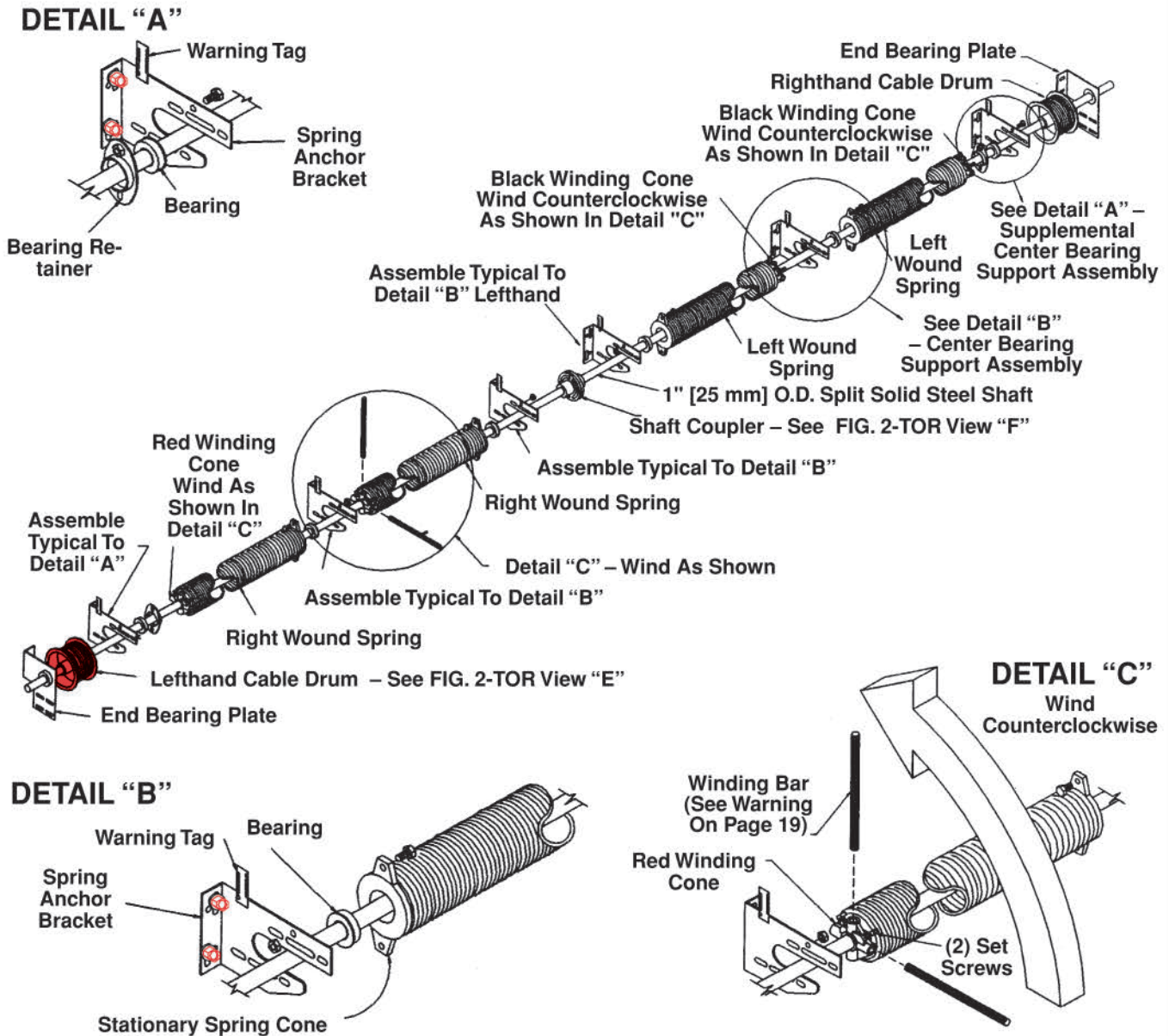

Fig. 3-TOR

Final Adjustment and Maintenance

Inside Slide Lock will be installed on the #2 section on preferred side. Line up the lock rod with the lock hole in the track (FIG. 8-S, page 12) making sure that when lock is in the unlocked position it doesn't extend past the end stile. Fasten lock to the end stile using (4) #14 x $\frac{5}{8}$ " [6 mm x 16 mm] sheet metal screws. Lubricate all moving parts (hinges, rollers, bearings, springs, etc.) with light weight oil. Do so when installed and thereafter about every six months. High use doors will require more frequent lubricating.

Every six months inspect your door for the following:



WARNING

Do not attempt to adjust door components unless you are a qualified door mechanic.

- Cables for fraying
- Torsion spring plugs and spring anchors
- Bearings in end bearing plates
- Rollers and hinges
- Track alignment
- Backhang angle and sway brace attachments
- Tighten all screws and nuts on bolts

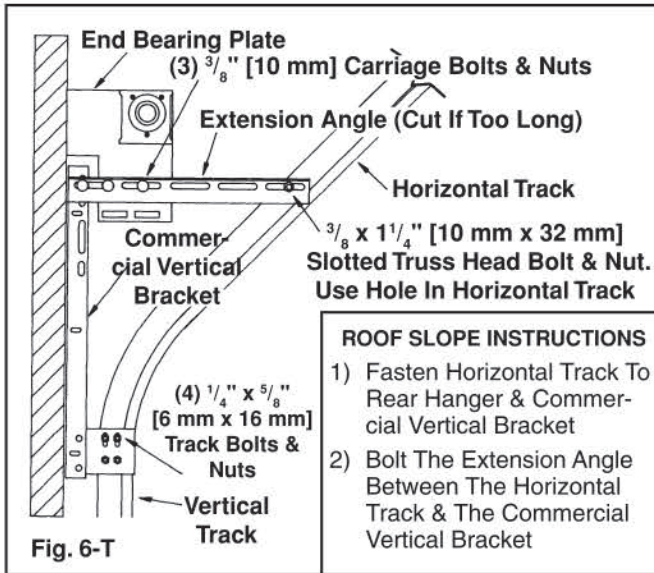

Roof Pitch

Horizontal track follows the pitch of the roof line. Track is assembled similar to standard lift, except that the horizontal angle is mounted level just above the radius. (FIG. 6-T) Everything is put together the same as type of track ordered. Installation follows standard radius track procedure.

Low Headroom Double Track (LHR)

LHR can be installed rear torsion (springs at back of horizontal track) up to a maximum door weight of 800 lbs., [363 kg] after that, it must be installed front torsion up to 1,200 lbs. [544 kg]. Front torsion is much easier to install, but it requires more headroom and the door will hang in the opening unless an electric operator is used.

The door hardware for LHR is the same as for standard radius except special outside bottom brackets are used to allow cable to ride on the outside of the track and the top bracket is flat with the top roller being the only one riding in the top track. (FIG. 7-T)

Install low headroom bottom brackets and cable using red-colored fasteners. (FIG. 8-T)

All struts will be applied according to strutting schedule on page 9, except the top strut will follow instructions below.

Top Section Strutting Procedure for LHR

With the top section face down on saw horses, place strut on top of section (section should be straight). Position top edge of strut approximately 1" [25 mm] down from top of door. At each center stile, fasten strut to center stile with (2) #14 x $\frac{5}{8}$ " [6 mm x 16 mm] self-drilling screws. The ends of the struts will require fastening in the same manner as the center stiles after the section has been installed and top brackets have been installed and adjusted.

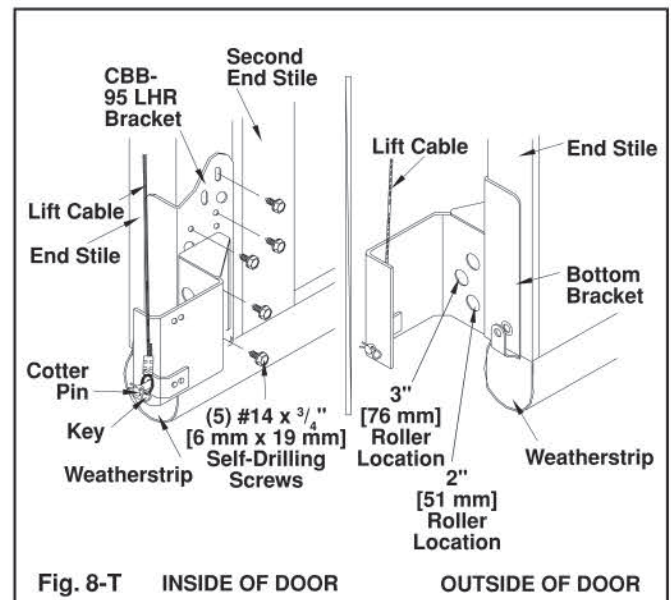
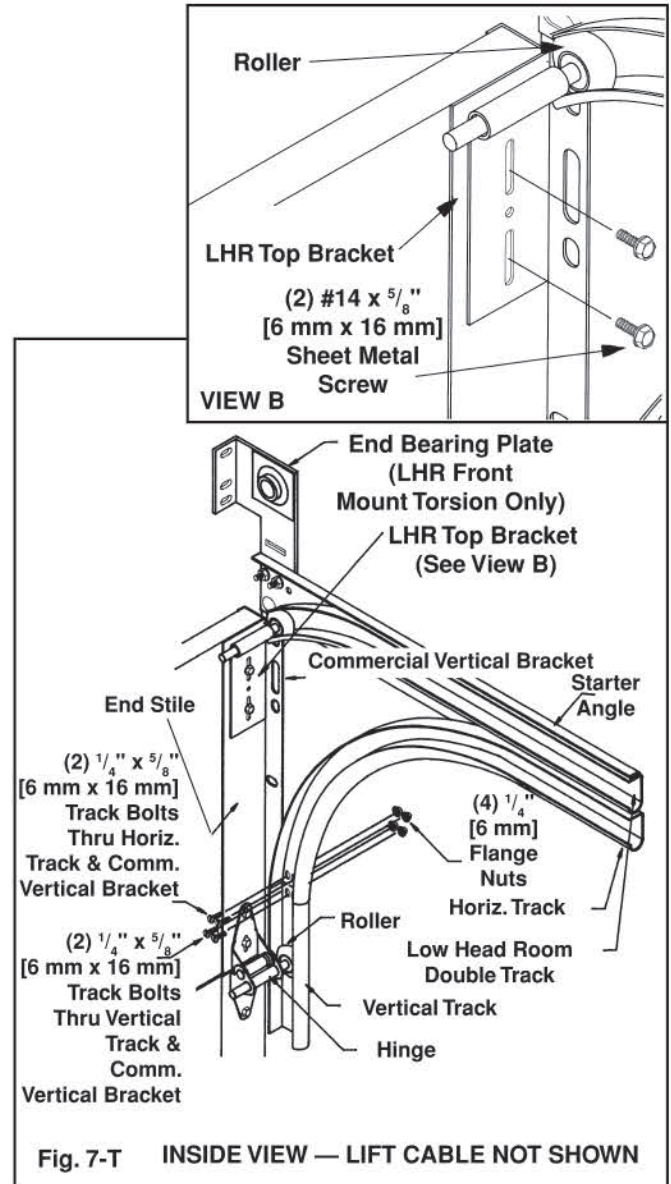

Low Headroom Top Brackets

All Door Models: Insert rollers in low headroom top brackets. On each side of door, insert each roller into the top horizontal track. Slide each low headroom top bracket down the top section until top section is tight against wood stop or steel jamb. If a top strut has been installed the top bracket will have to be placed between stile and strut. Line each low headroom top bracket up with the side of the top section. Using both slots in each low headroom top bracket as a guide, drill

$\frac{3}{16}$ " [5 mm] pilot holes in the center of each slot leaving room for final adjustment in both directions.

Steel Door Models: Attach each low headroom top bracket with two #14 x $\frac{5}{8}$ " [6 mm x 16 mm] sheet metal screws. (FIG. 7-T, page 23)

Rear Mount Torsion Spring Doors

Attach horizontal track to vertical bracket using $\frac{1}{4}$ " x $\frac{5}{8}$ " [6 mm x 16 mm] track bolts and flange nuts. Attach horizontal angle to the vertical angle using $\frac{3}{8}$ " x $\frac{3}{4}$ " [10 mm x 5 mm] carriage bolts and flange nuts. The end bearing plate will be positioned and fastened as shown in Figure 9-T. Some drilling in end bearing plate and horizontal angle may be required.

For doors over 350 pounds [159 kg], install the 5" [127 mm] pulley as illustrated in Figure 9-T, View C. The carriage bolts used must be installed with the heads toward the inside of the track and the nuts facing outside as in the illustration. The cable must be routed through the pulley saddle prior to attaching to drum.

Rear torsion spring doors will require that springs be placed at rear of track and a center support hanger(s) be provided that is strong enough to withstand the torque of the springs. Rear of horizontal tracks must be securely fastened in the proper position before springs are wound or door is lifted. Doors over 12' [366 cm] high will require two backhangs for each horizontal track. Horizontal tracks should be level and backhung according to Figure 9-T. (See important note on page 17 for additional backhang requirements.) All backhang material is supplied by installer due to ceiling height differences.

Install springs according to Figure 10-T and wind. See spring winding on page 18 for more information. Push track towards jambs until door is tight against stop or steel jambs and tighten track bolts. Adjust top brackets (FIG. 7-T, page 23) by sliding it up or down on door in order to position top section correctly.

Install the inside slide lock or lock bars (page 12) after springs are wound. Nail door stop in place if applicable.

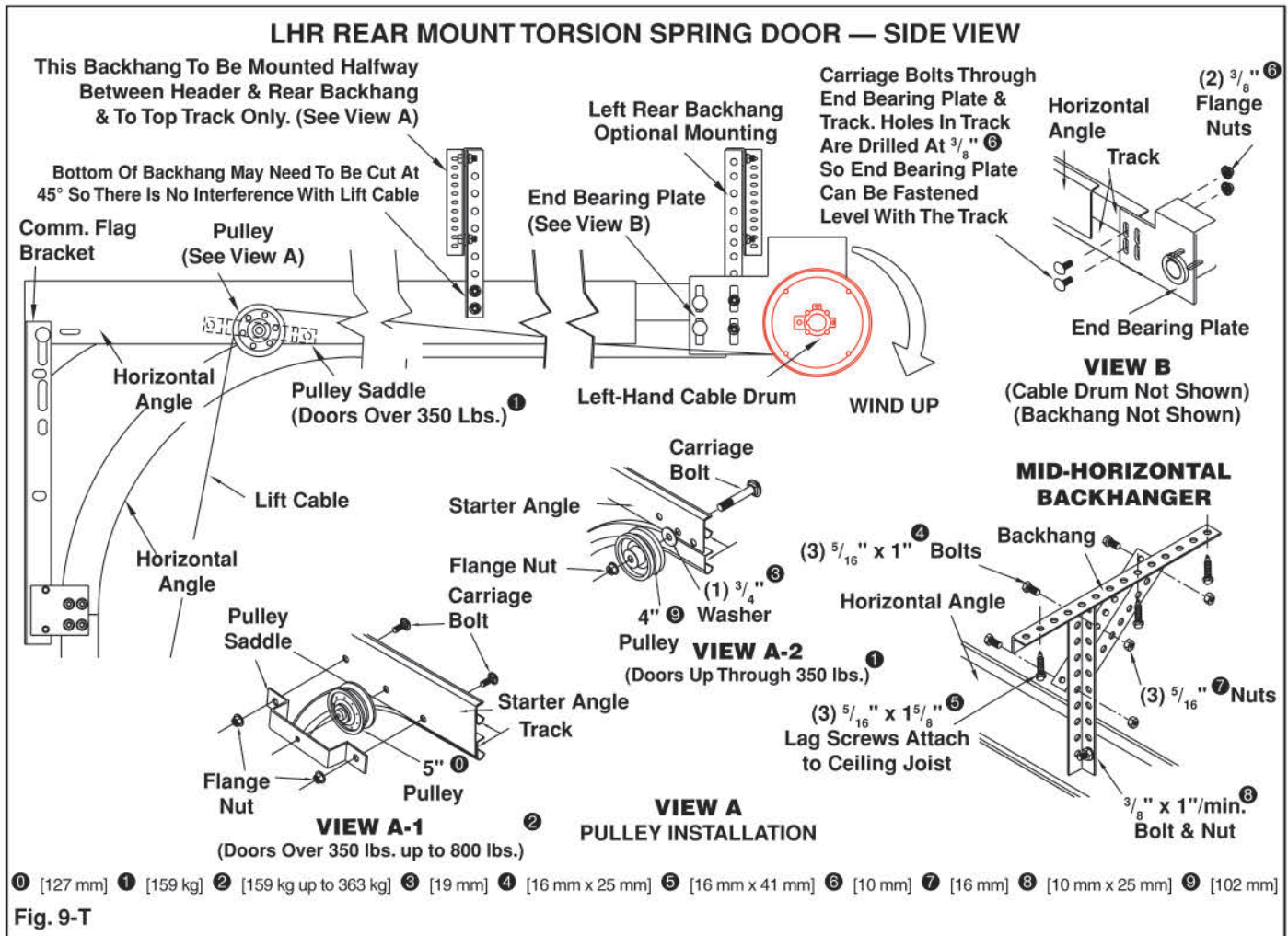

LHR REAR MOUNT TORSION SPRING DOOR — REAR VIEW

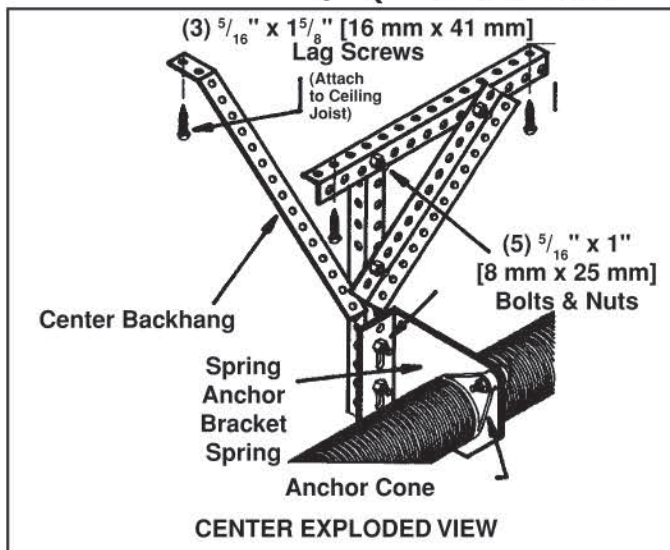
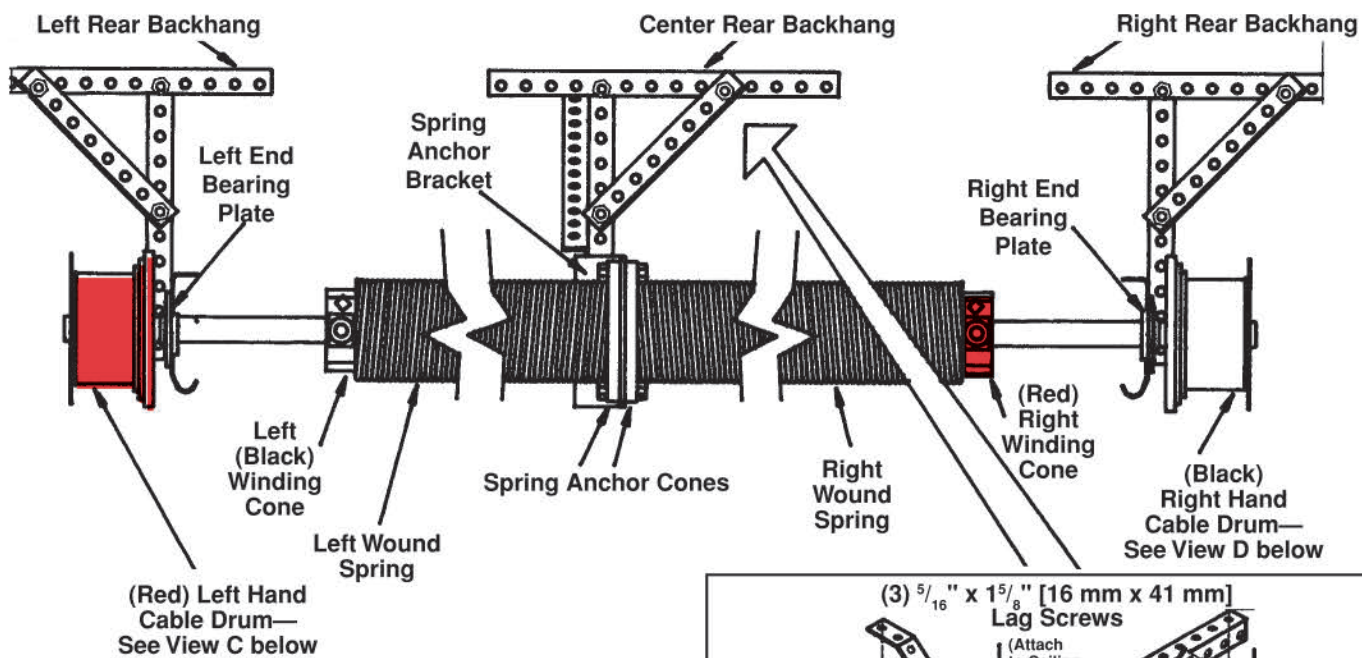
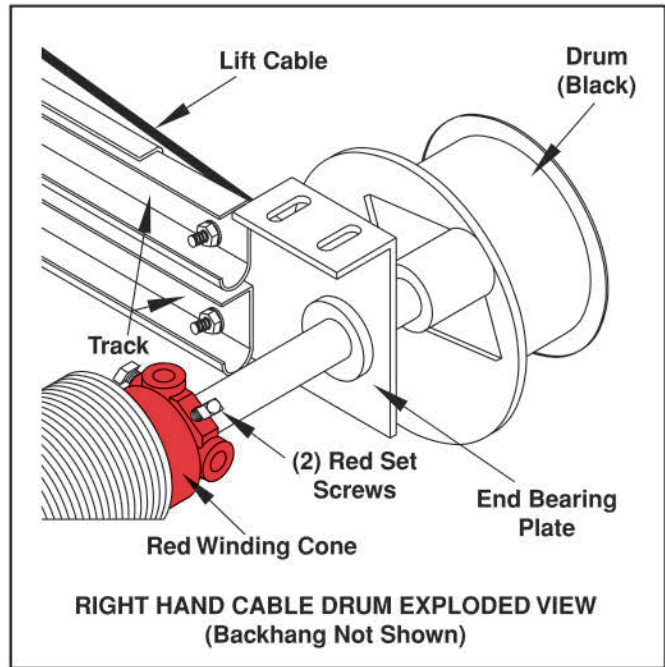
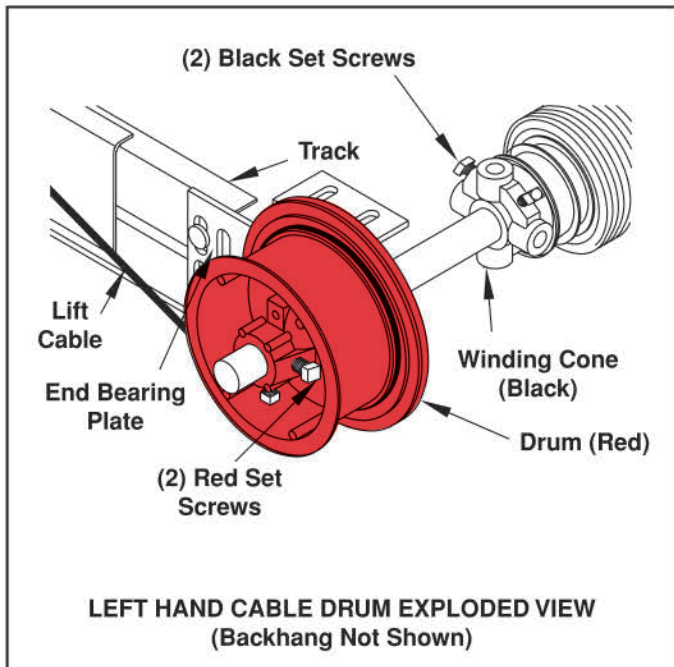

Fig. 10-T



LHR Front Mount Torsion Spring Doors

Attach horizontal track to vertical bracket using $\frac{1}{4}$ " x $\frac{5}{8}$ " [6 mm x 16 mm] track bolts and flange nuts. Attach horizontal angle using $\frac{3}{8}$ " x $\frac{3}{4}$ " [10 mm x 19 mm] carriage bolts and flange nuts. The end bearing plate will be positioned and fastened as shown in Figure 11-T. Some drilling in horizontal angle may be required. (FIG. 7-T, page 24)

Install springs according to Figure 12-T, and wind. See spring winding on page 19 for more information.

Raise door so that only two sections are in the horizontal tracks. Align horizontals so that spacing is equal from front to back. Backhang door as shown in Figure 6-T. (**See important note on page 17 for additional backhang requirements.**) Raise door all the way and check for proper track alignment. Realign horizontal track if required.

Push track (if adjustable) towards jambs until door is tight against stop or steel jambs and tighten track bolts. Adjust top brackets by sliding it up or down on door in order to position top section correctly. (FIG. 7-T) Install the inside slide lock or lock bars (page 12) after springs are wound. Nail door stop in place if applicable.

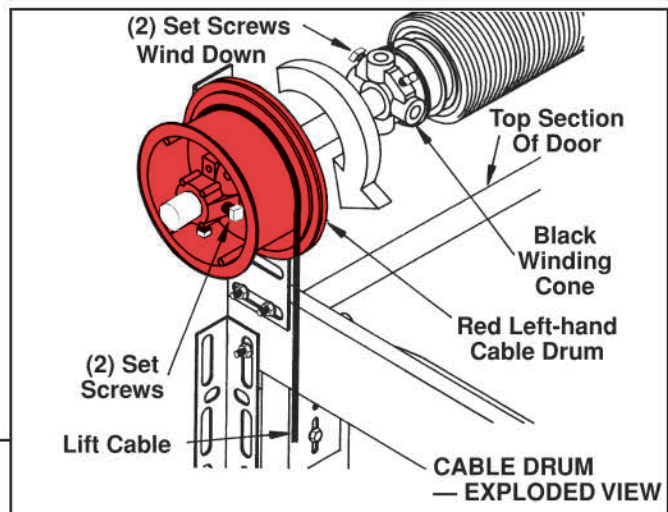
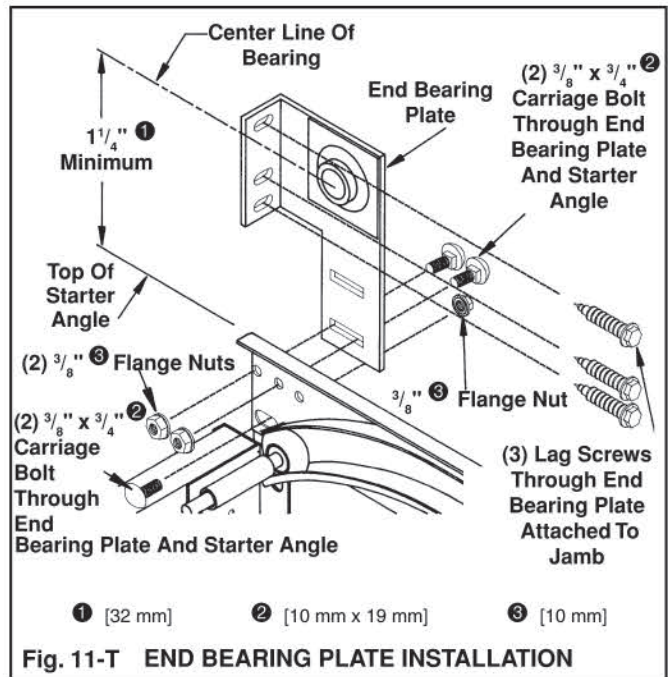

LHR FRONT TORSION SPRING DOORS

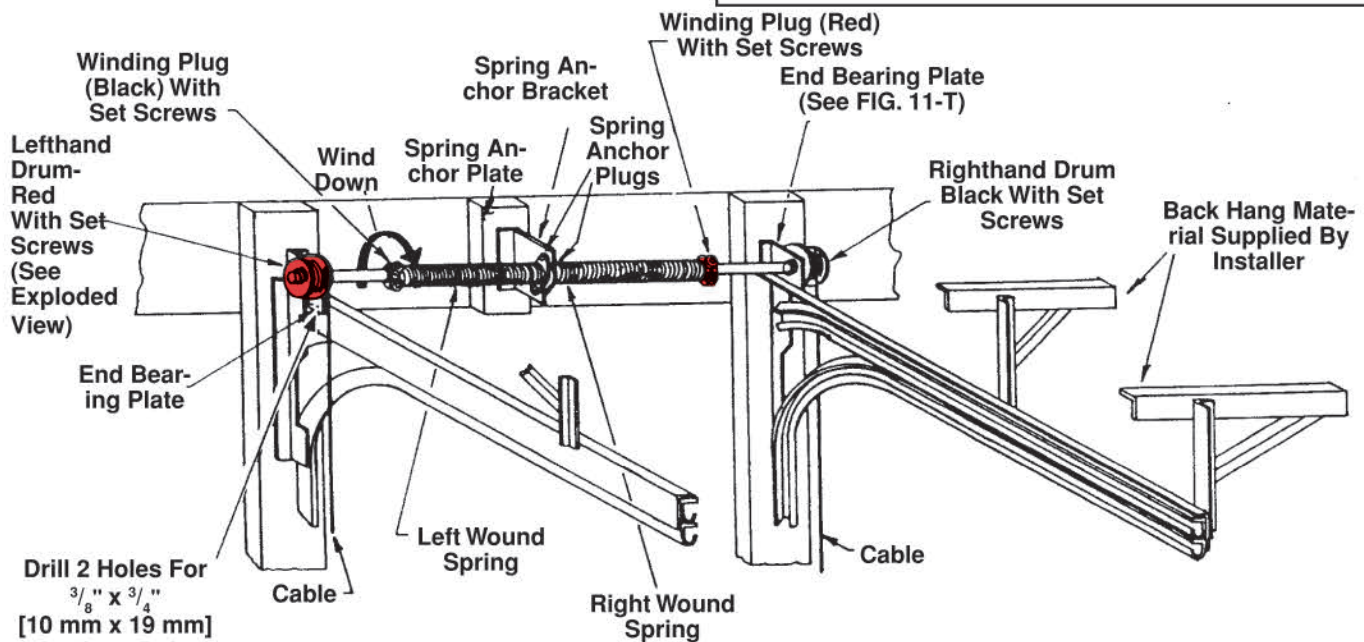

Fig. 12-T

Vertical Lift Track

Vertical lift tracks are built as one piece or as two pieces per side, depending on door height. Follow the vertical track information (Step 1, page 15) for the lower part of the track, from the floor to the top of the door.

Starting at the top of the door, plumb one track and lag or screw it to the wall all the way up. Measure the width of the tracks at the top of the door and set the very top of the second vertical track at the exact same distance. Finish fastening the center of the vertical track, making sure the distance between the tracks is equal from the top of the door on up. Install top section to other sections. (FIG. 9-S, page 12)

Attach the bearing plates as shown in Figure 13-T. See spring winding information, page 19 for installing and winding springs.

IMPORTANT: Do not cut cables. It may seem like the cables are too long, but they are not. Wind the extra cable onto the drums.

All vertical lift doors must be sway braced as in Figure 13-T.



WARNING

Door may fall out of track if the track is improperly aligned.

Attach spring bumpers as shown in Figure 14-T. They will keep door from coming out of top of the track. Position bumpers so that door clears the opening and drill in place using $\frac{5}{16}$ " x 1" [8 mm x 25 mm] hex head bolts to fasten.



WARNING

Door may come out of track if spring bumper is not installed.

Push lower vertical track towards jambs until door is tight against stop or steel jambs and tighten track bolts. Adjust the bottom of the upper vertical track to align with the top of the lower vertical track and tighten the track bolts.

Adjust top brackets. (FIG. 9-S, page 12) Install inside slide lock or lock bars after springs are wound. (FIG. 7-S & 8-S, page 12) Nail door stop in place if applicable.

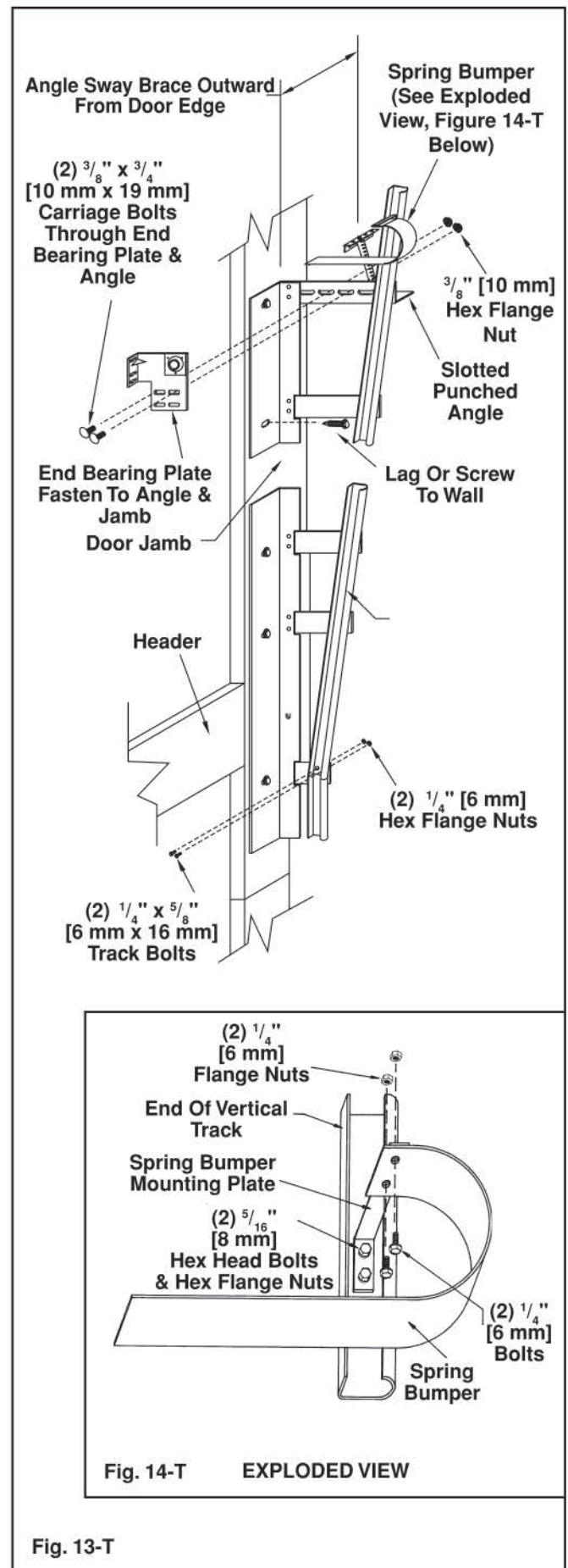

Fig. 13-T

High Lift Track

Some smaller high lift doors will come with vertical tracks in one piece plus the horizontal tracks. Larger high lift doors will have the vertical track in two pieces plus the horizontals. Follow the vertical track information (Step 1, page 16) for the lower part of the track from the floor to the top of the door. Starting at the the door, plumb one vertical track and lag or screw it to the wall all the way up. Measure the width of the tracks at the top of the door and set the very top of the second track at the exact same distance. Finish fastening the center of the vertical track, making sure the distance between the tracks is equal from the top of the door on up. Attach the horizontal tracks using $\frac{1}{4}$ " x $\frac{5}{8}$ " [6 mm x 16 mm] track bolts and $\frac{3}{8}$ " x $\frac{3}{4}$ " [10 mm x 19 mm] carriage bolts to attach the horizontal angle. Rig a temporary rope to support back of horizontal tracks. They should be level (parallel) to 1" [25 mm] higher in back. Attach the bearing plates as shown in Figure 15-T. Install top section to other sections. (FIG. 9-S, page 12) See spring winding information for installing and winding springs.

IMPORTANT: Do not cut cables. It may seem like the cables are too long, but they are not. Wind the extra cable onto the drums.

After the springs have been installed and wound, raise the door so that only the two top sections are in the horizontal track. Secure the door in place with locking pliers on track above a roller making sure it can't be raised. Backhang doors as shown in Figure 17-T. Any door with a horizontal track 11' 6" [350 cm] long or longer requires two backhangs on each horizontal track. (FIG.17-T) (See important note page 17 for additional backhang requirements.) Attach spring bumpers as shown in Figure 16-T. They will keep the door from coming out of the back of the tracks. Push the door against the stop or steel jambs and tighten track bolts. Adjust top brackets. (FIG. 9-S, page 12) Install inside slide lock or lock bars after springs are wound. (FIG. 7-S & 8-S, page 12) Nail door stop in place if applicable.

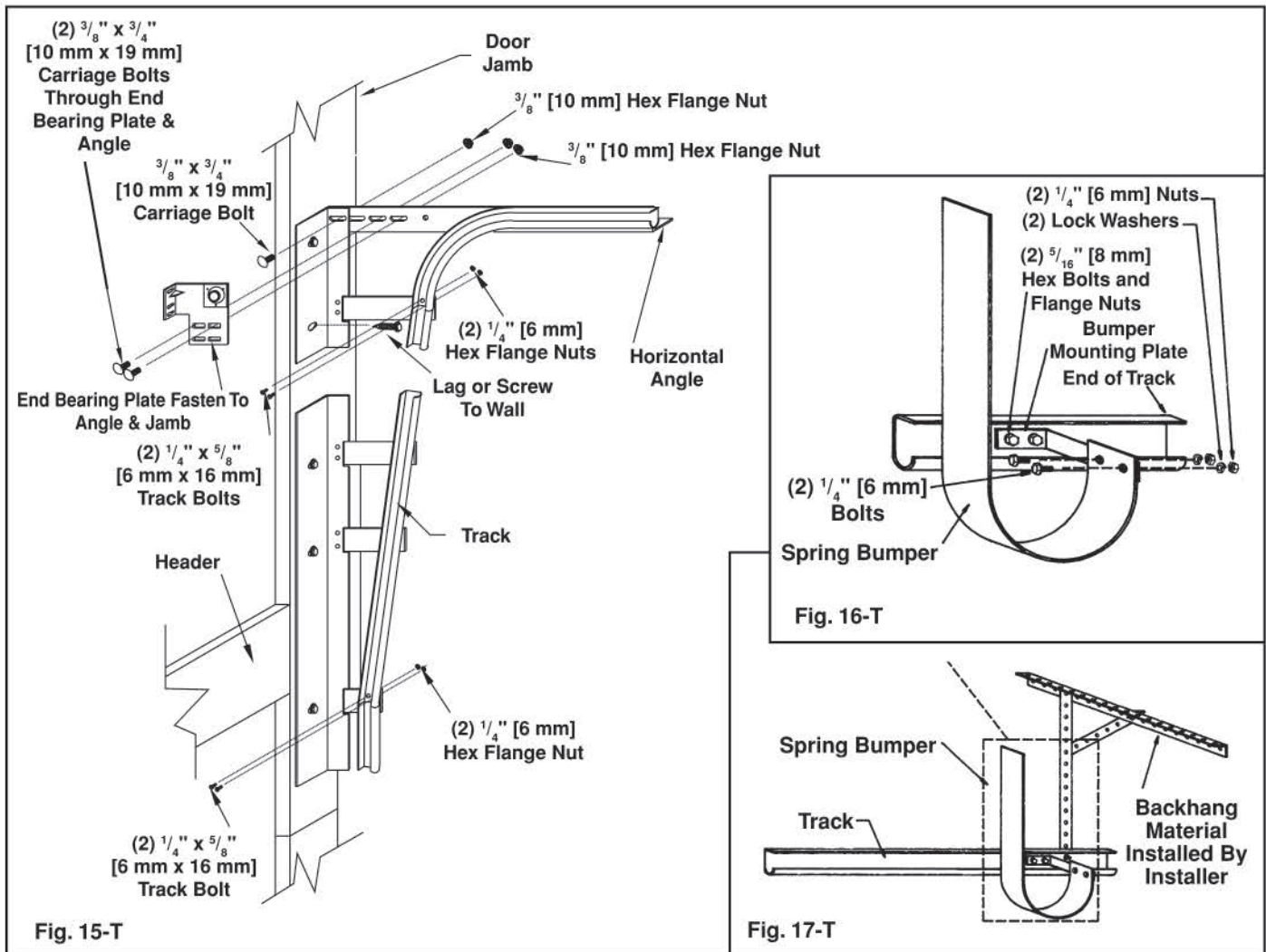

Attaching an Automatic Opener



WARNING

To avoid risk of strangulation or personal injury to children, you must remove the pull down rope when you install an automatic garage door operator.

NOTE: Failure to reinforce the door as illustrated will void Clopay Warranty.

Doors with a stile at center of door:

- You will need three pieces of 14 gauge 2" x 2" [51 mm x 51 mm] punched angle iron. Two pieces should be 8 ft. [244 cm] long and one at least 24" [610 mm] long. The 24" [610 mm] piece may have to be trimmed to fit your door.
- Remove the fasteners from the top half of the three top section hinges closest to, or at, the center of the door. One 8 ft. [244 cm] piece of angle iron is to span across these three hinges and attached using fasteners previously removed.
- Place remaining 8 ft. [244 cm] piece across the top of the section, bridging across the same three stiles as the bottom angle. Attach with fasteners similar to ones used with the hinges. One fastener per stile. If your door has a strut at the top of the section, remove the bottom strut clips and overlap the flange of the strut with the angle iron to secure the bottom of the strut. Attach angle using the fasteners removed with the strut clips. (FIG. 1-OP) Refer to Figure 3-OP for C-Channel.
- Cut the 24" [610 mm] piece of punched angle iron to span from top horizontal angle to bottom horizontal angle. Place vertical angle directly above stile in the center of the door. Attach vertical angle through both the top and bottom horizontal angles to the stile beneath with fasteners similar to ones used with the hinges.

Doors without stile at center of door:

- You will need three pieces of 14 gauge 2" x 2" [51 mm x 51 mm] punched angle iron. Two pieces should be 4 ft. [122 cm] long and one at least 24" [610 mm] long. The 24" [610 mm] piece may have to be trimmed to fit your door.

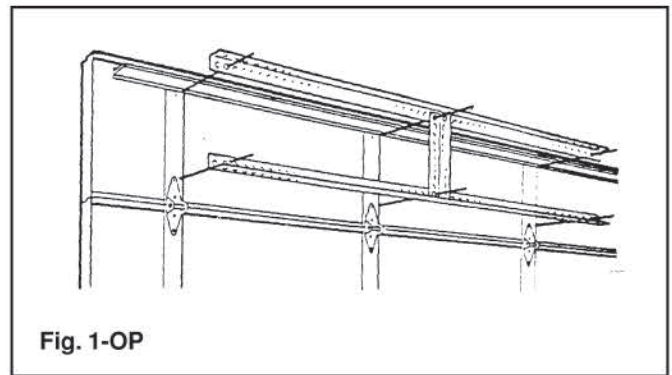

Fig. 1-OP

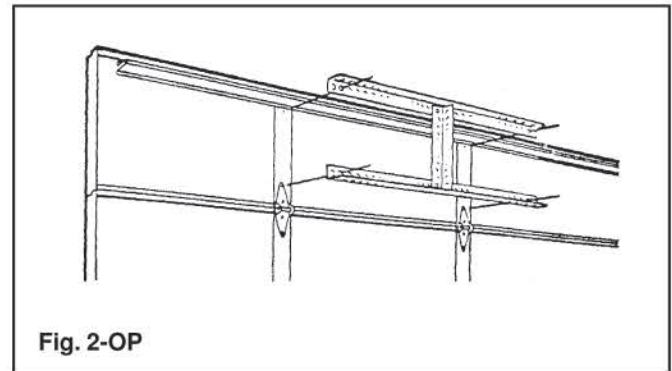

Fig. 2-OP

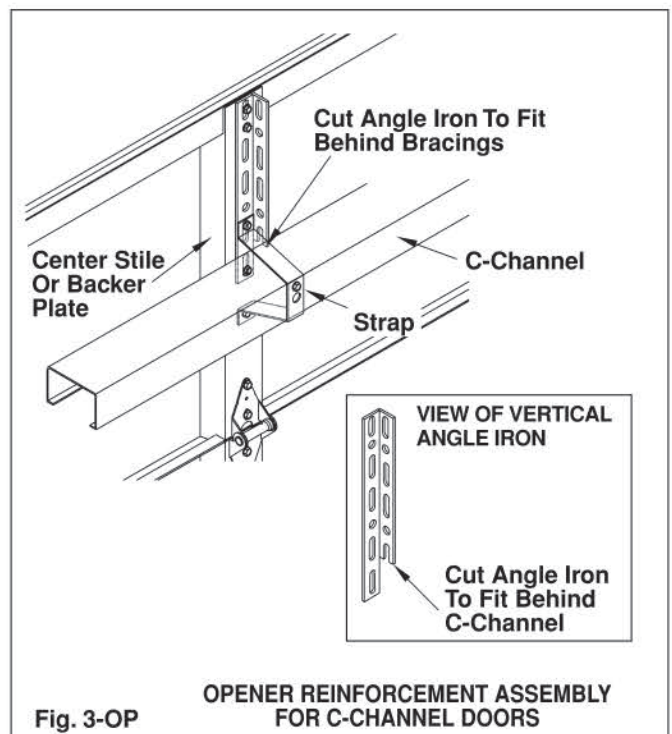

Fig. 3-OP

- Remove the fasteners from the top half of the two top section bottom hinges closest to the center of the door. One 4 ft. [122 cm] piece of angle iron is to span across these two hinges and is attached using fasteners previously removed.
- Place remaining 4 ft. [122 cm] piece across the top of the section, bridging across the same two stiles as the bottom angle. Attach with fasteners similar to ones used with the hinges. One fastener per stile. If your door has a strut at the

top of the section, remove the bottom strut clips and overlap the flange of the strut with the angle iron to secure the bottom of the strut. Attach angle using the fasteners removed with the strut clips. (FIG. 2-OP)

- Cut the 24" [610 mm] piece of punched angle iron to span from top horizontal angle to bottom horizontal angle. Place vertical angle directly in the center of the door. Attach vertical angle to both the top and bottom horizontal angles with two $\frac{3}{8}$ " [10 mm] nuts and two $\frac{3}{8}$ " [10 mm] bolts. Refer to Figure 3-OP for C-Channel.

Attach the operator arm of garage door opener to the short vertical angle. The operator arm must be attached roughly at the same height of the top rollers of the door.

Painting and Windows

PAINTING

Cleaning: Before painting your door, it must be free of dirt, oils, chalk, waxes and mildew. The pre-painted surfaces can be cleaned of dirt, oils, chalk and mildew with a diluted solution of trisodium phosphate. Trisodium phosphate is available over the counter at most stores under the name SOIL-AX®, in many laundry detergents without fabric softener additives, and in some general purpose cleaners. Check the label for trisodium phosphate content. The recommended concentration is $\frac{1}{3}$ cup [79 ml] of powder to 1 $\frac{1}{2}$ to 2 gallons [6 l to 8 l] of water. After washing the door, always rinse well with clear water and allow to dry.

If the door has ever been waxed, the wax must be removed before painting. Doors are not waxed during the manufacturing process. This can be accomplished by wiping the door surface with a rag saturated with Xylene (Xylol), available at most paint or hardware stores. Wiping should be done at moderate pressure and Xylene must not be allowed to sit on the door for an extended time. Damage to your door's paint system can occur if overexposed to this or other solvents.

Caution: Safety instructions on the solvent's container must be followed. After de-waxing the door, clean with trisodium phosphate, as stated previously.

NOTE: Sanding could remove rust-inhibiting compounds, therefore, sanding should be done only

to damaged areas where bare metal has been exposed. Refer to the "Repair" section of these instructions.

Repair: Should your door's paint finish become damaged, exposing the bare metal, it will become necessary to repair this area to prevent rust from forming. The damaged area should be lightly sanded with a medium to fine sandpaper making sure to remove all visible red and white rust. Wipe this area with a dry, clean rag. Coat the sanded area with a high quality, rust inhibiting, zinc enriched primer. This type of primer can be found at most paint or hardware stores, and should be labeled for covering bare and galvanized steel. Once the primer is applied, wait the time specified on the primer's instructions before you finish painting your door.

Paint: Your steel garage door can be painted with a high-quality flat latex exterior grade paint. Since all paints are not created equal, the following test needs to be performed: paint should be applied on a small area of the door (following the instructions on the paint container), allowed to dry, and evaluated prior to painting the entire door. Paint defects to look for are blistering and peeling. An additional test is to apply a strip of masking tape over the painted area and peel back, checking to see that the paint adheres to the door and not to the tape.

After satisfactorily testing a paint, follow the directions on the container and apply to the door. Be sure to allow adequate drying time should you wish to apply a second coat.

With the exception of rubber gasket windows, window frames & inserts can be painted with a high quality latex paint. The plastic should first be lightly sanded to remove any surface gloss.

NOTE: Do not apply paint when door surface temperature is different from manufacturer's suggested temperature range for application.

WINDOWS WITH SCREW-DOWN FRAMES



WARNING

To avoid injury, use extreme caution in handling glass window pane. When the frame is removed, the exposed steel edge of the door may be sharp. Avoid contact with the steel edges.

Glass Replacement: If your door is equipped with windows and the glass should need replacement, follow the steps below:

- 1) With someone holding the outside frame, remove the ten screws from the inside window frame.
- 2) Pull the inside frame out of the door.
- 3) **Carefully** remove the broken or old glass.
- 4) Insert the new (replacement) glass.
- 5) With someone holding the outside frame, reinsert the screws into the inside frame, trapping the glass.

Quick Turn Bracket

(Reduces headroom requirement by 2" [51 mm]. Quick turn bracket cannot be used in conjunction with any other low headroom option.) This is used in place of the existing top roller.

1. Place two rollers in the tubes as shown. On some doors it will be necessary to try various roller positions to achieve the proper hinge location on the door. (FIG. 1-LHR)
2. Position the rollers and the bracket in the door track. Allow the hinged end of the bracket to come against the door. Apply sufficient pressure to be sure that the top of the door is closed tightly against the header.
3. Attach to the top of the door in the same manner as the original top roller bracket.
4. It may be necessary to relocate holes.

Pass Door Installation

NOTE: Proper alignment of the pass door frame is critical for smooth operation of the pass door. After stacking the bottom section, measure the pass door frame opening at the top and bottom of the frame (Figure 3-PD). If this measurement is not exactly the same, the bottom section will need to be shimmed or clamped so that the frame is aligned.

See Figure 1-PD (Deep Ribbed Steel Doors) or Figure 2-PD (Double Skinned Insulated Doors) for diagram of pass door showing hinge and closer locations. The strut schedule for pass doors follows the strut schedule on page 9, minus 2 struts.

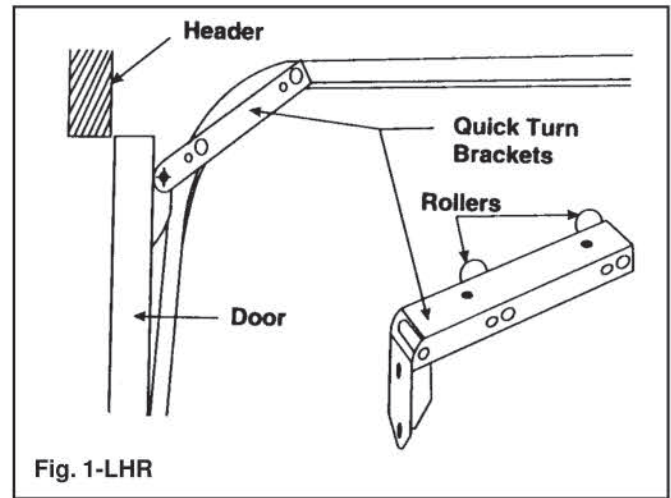
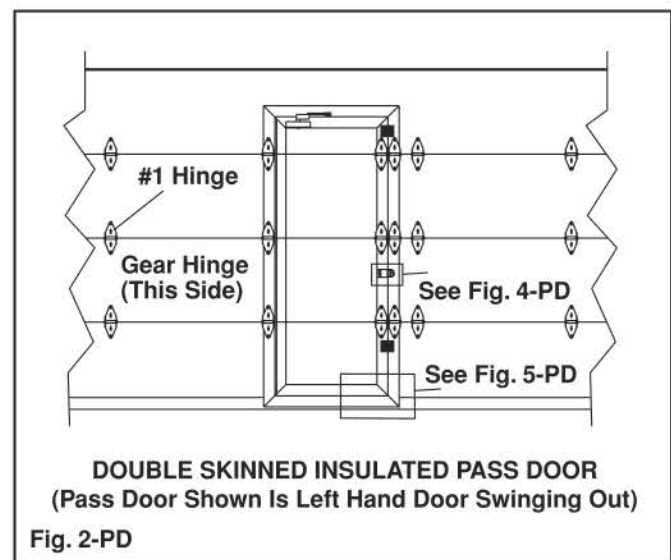
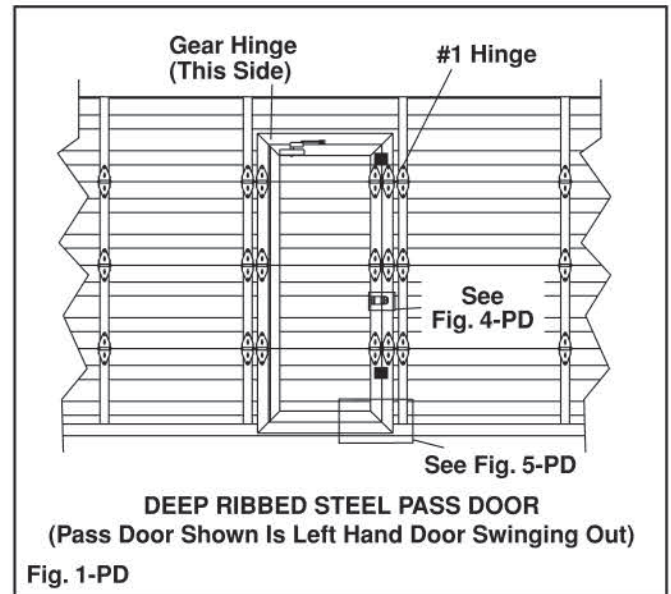

Fig. 1-LHR



NOTE: Swinging portion of Pass Door on bottom section may need to be shimmed up during installation of upper sections to prevent gapping. (FIG. 5-PD)

NOTE: To better ensure proper alignment of the frame from section to section, install the center hinges on the gear hinge side of the aluminum pass door frame first and work outwards installing hinges.

Install Lock according to Figure 4-PD.

Install closer according to the closer instructions provided.

